

**March 5 - 10, 2017**

The Cliff Lodge and Spa  
Snowbird, Utah



# 47<sup>TH</sup> ANNUAL MEETING



# FINAL PROGRAM

**SAVE THE DATE**

**Western Trauma Association**

**48th Annual Meeting**

**February 28 - March 2, 2018**

Fairmont Chateau Whistler

Whistler, British Columbia



# **FORTY-SEVENTH ANNUAL MEETING**

**March 5 - 10, 2017  
Snowbird, Utah**

Dear Members, Friends and Guests:

On behalf of the Officers and Board of Directors, I want to warmly welcome you to the 47th Annual Meeting of the Western Trauma Association in Snowbird, Utah. I went to my first WTA meeting here in 1997 and the mountain is dear to me for that reason. But for a variety of reasons, we haven't been back since 2003 and that's way too long! Snowbird is one of the most wonderful and diverse ski mountains in the United States, and we have also made arrangements for those who are interested to ski over to Alta. Together, these two areas have more skiable terrain any Center in the United States. But there are many reasons why Snowbird is an ideal place for the WTA to meet. It has spacious meeting rooms and inter-connected buildings that allow us to go back and forth to our meetings in our ski gear if we want. Also, Snowbird is famous for its ski school, especially its' children's program. But in addition, this year we have arranged for Group lessons for WTA adults who we also hope will ski with our new WTA arm bands, all meant to help us recognize each other on the slopes and so build old and new friendships. Check in with the registration desk. All in all, we expect to have a lot of fun, do a lot of important scientific work, and help build young surgical careers.

Rick Miller's program committee created a first-rate scientific program that's available at [www.westerntrauma.org](http://www.westerntrauma.org) and in the program book. 36 abstracts were selected for oral presentation including 10 Earl Young competition papers. Four papers present the product of WTA multicenter trials. We will hear 5 case reports and 3 family abstracts. The algorithms committee will suggest pathways for abdominal stab wounds, REBOA use, Burn care and Renal trauma. Pro-Con Debates will address prediction of survivability after TBI and use of rib plating.

Mitch Cohen's Founders Lecture is entitled "Translational Approaches to Acute Traumatic Coagulopathy". Dr. Ken Waxman will present the Paint the Ceiling lecture, entitled "From the Other Side: My Daughter, Cancer and Me". My Presidential address will be entitled "Ownership", and address the changes in our practice that have allowed control of our patients care to slip out of our hands...

We will also feature two panels of experts, and a “Clash of the Generations” where young faculty, full of piss and vinegar, face-off with grizzled trauma veterans to see who gets “voted off the mountain!”

The Social Program includes classic WTA events like the Sunday welcome reception, but at Monday noon, we also feature the new Mountain mentoring lunch, where senior faculty meet aspiring surgeons to eat turkey and then talk turkey about their careers. Monday night features a residents’ reception where junior faculty can hang, chill, and go to sleep late. Simultaneously, the WTA family night will allow old friends to hang out, drink and go to sleep early! Tuesday will feature the presidential address at 5 PM. Wednesday features the NASTAR race with the Mountain Barbeque to follow. The Book Club meets Wednesday 4-6 PM. The Paint the Ceiling lecture is Thursday 5PM. Finally, the Thursday night banquet will have ski awards, fun, and a special musical event featuring the incredible voice of the WTA’s own songstress, Maria-Jacqueline Hauser. We close with a dance party featuring musical favorites from the President’s 35 years in the Grammy Society – so be READY TO ROCK!

The WTA is science, collegiality, family and friends. Snowbird is a place for us to learn, teach, ski make new friends and new colleagues, and the prevailing winds have been so good to us this year! Snowbird has a >100” base everywhere on the mountain and is in an active storm track again this week. I can hardly wait. MJ and I are delighted to host what we predict will be a wonderful week where science, music and champagne Utah powder greet “the fellowship of the snows”.

Much love to you all.



**Carl J. Hauser, MD**

*President, Western Trauma Association*



# TABLE OF CONTENTS

Page 2	<b>CME Information</b>
Page 4	<b>Learning Objectives</b>
Page 5	<b>Disclosure Information</b>
Page 8	<b>Mission Statement</b>
Page 9	<b>2016-2017 Officers &amp; Committee Information</b>
Page 11	<b>Past Presidents</b>
Page 13	<b>New Members</b>
Page 14	<b>WTA Foundation Donors</b>
Page 17	<b>In Memoriam</b>
Page 18	<b>Earl Young Competition</b>
Page 20	<b>Presidential Address</b>
Page 22	<b>“Paint the Ceiling” Lectureship</b>
Page 24	<b>Founders’ Basic Science Lectureship</b>
Page 27	<b>Agenda</b>
Page 40	<b>Abstracts</b>
Page 151	<b>Membership Directory</b>

# CME INFORMATION

## CONTINUING MEDICAL EDUCATION CREDIT INFORMATION

### Accreditation

This activity has been planned and implemented in accordance with the Essential Areas and Policies of the Accreditation Council for Continuing Medical Education (ACCME) through the joint providership of the American College of Surgeons and Western Trauma Association. The American College of Surgeons is accredited by the ACCME to provide continuing medical education for physicians.

### AMA PRA Category 1 Credits™

The American College of Surgeons designates this live activity for a maximum of 18.75 AMA PRA Category 1 Credits™. Physicians should claim only the credit commensurate with the extent of their participation in the activity.

Of the AMA PRA Category 1 Credits™ listed above, a maximum of 15.50 credits meet the requirements for Self-Assessment.

Of the AMA PRA Category 1 Credits™ listed above, a maximum of 18.75 credits may qualify as **Trauma**.\*

*\* The content of this activity may meet certain mandates of regulatory bodies. ACS has not and does not verify the content for such mandates with any regulatory body. Individual physicians are responsible for verifying the content satisfies such requirements.*



AMERICAN COLLEGE OF SURGEONS  
Inspiring Quality:  
Highest Standards, Better Outcomes



AMERICAN COLLEGE OF SURGEONS  
DIVISION OF EDUCATION  
Accredited with Commendation by the  
Accreditation Council for Continuing Medical Education



# CME INFORMATION

## TO CLAIM CME

You can access the Meeting Evaluation and Self-Assessment tests from the WTA Meeting App. You will also receive an email with instructions. We are using a new system this year so the process will look a little different. Your username will be the email address you used to register for the meeting. Your password will be your Last Name (first initial capitalized).

## MEETING APP INSTRUCTIONS

Download the WTA Meeting App on your iOS or Android device. The Schedule of Events, Attendee List, Abstracts and Self-Assessment tests can be found on the app.



View the Vimeo video for downloading an app on iOS - first time users - <https://vimeo.com/155553890>

Downloading the app is easy on iOS and Android! Instructions:

1. Visit <http://my.yapp.us/WTAMEETING> on your device and follow instructions on the page
2. You'll be asked to install Yapp from the app store. (if you don't have it already)
3. Open Yapp and tap "Download an existing Yapp" and your app will appear.

## Don't have an iOS or Android device?

You can view this app from your desktop browser by clicking the [my.yapp.us](http://my.yapp.us) URL above.

# LEARNING OBJECTIVES

This activity is designed for physicians of all specialties who are involved in the care of trauma patients.

Upon completion of this course, attendees will be able to:

- Describe the use of a smart-phone based infrared imaging to provide assessment of limb perfusion and tourniquet effectiveness
- Review clinical and pre-clinical trials plus basic science research in pertinent topics in trauma including: traumatic brain injury, hemorrhagic shock and Thrombo-embolic phenomenon, cervical spine evaluation and clearance, peptic ulcer prophylaxis and delirium
- Analyze 4 algorithms to aid clinicians in the management of abdominal stab wounds, renal trauma, burns and the use of REBOA for exsanguinating hemorrhage.
- Illustrate the use of thoracic irrigation to prevent retained hemothorax and peritoneal lavage to potentially reduced the risk of the systemic inflammatory response
- Analyze 4 multicenter trials in a) cervical clearance in intoxicated patients, b) Mortality after emergency trauma laparotomy, c) Management of subclavian and axillary artery injuries using open and endovascular techniques d) Use of TEVAR as the new standard for blunt thoracic aortic injuries.
- Discuss the natural history of splenic vascular abnormalities after blunt trauma
- Evaluate prehospital novel initiatives to identify geographic areas of high levels of intentional injury and target preventive measures
- Examine the use of social media as an early warning signal for mass casualty alertness

# DISCLOSURE INFORMATION

In accordance with the ACCME Accreditation Criteria, the American College of Surgeons, as the accredited provider of this activity, must ensure that anyone in a position to control the content of the educational activity has disclosed all relevant financial relationships with any commercial interest. Therefore, it is mandatory that both the program planning committee and speakers complete disclosure forms. Members of the program committee were required to disclose **all** financial relationships and speakers were required to disclose any financial relationship **as it pertains to the content of the presentations**. The ACCME defines a 'commercial interest' as "any entity producing, marketing, re-selling, or distributing health care goods or services consumed by, or used on, patients". It does not consider providers of clinical service directly to patients to be commercial interests. The ACCME considers "relevant" financial relationships as financial transactions (in any amount) that may create a conflict of interest and occur within the 12 months preceding the time that the individual is being asked to assume a role controlling content of the educational activity.

ACS is also required, through our joint providership partners, to manage any reported conflict and eliminate the potential for bias during the activity. All program committee members and speakers were contacted and the conflicts listed below have been managed to our satisfaction. However, if you perceive a bias during a session, please report the circumstances on the session evaluation form.

**Please note we have advised the speakers that it is their responsibility to disclose at the start of their presentation if they will be describing the use of a device, product, or drug that is not FDA approved or the off-label use of an approved device, product, or drug or unapproved usage.**

The requirement for disclosure is not intended to imply any impropriety of such relationships, but simply to identify such relationships through full disclosure and to allow the audience to form its own judgments regarding the presentation.

# DISCLOSURE INFORMATION

SPEAKERS / MODERATORS / DISCUSSANTS	NOTHING TO DISCLOSE	DISCLOSURE		
		COMPANY	ROLE	RECEIVED
Carlos Brown	X			
Christine Cocanour	X			
Mitch Cohen	X			
Marc DeMoya	X			
Alex Eastman	X			
Matt Eckert	X			
Oscar Guillamondegui	X			
Oliver Gunter	X			
Jennifer Gurney	X			
Carl Hauser	X			
Kenji Inaba	X			
Jerry Jurkovich	X			
Manny Lorenzo	X			
Ajai Malhotra	X			
Matthew Martin	X			
Matt Martin	X			
Rick Miller	X			
Laura Moore	X			
Raminder Nirula	X			
Kimberly Peck	X			
Susan Rowell	X			
Tom Scalea	X			
Deb Stein	X			
Eric Toshlog	X			
Gary Vercruyssen	X			
Ken Waxman	X			
Jamie Anderson	x			
Christopher C. Baker	x			
Christopher D. Barrett	x			
Morgan Barron	x			
Richard D. Betzold	x			
Eric H. Bradburn	x			

# DISCLOSURE INFORMATION

Gabrielle Briggs	x			
Rachael A Callcut	x			
Ronald Chang	x			
Paul J. Chestovich	x			
Mackenzie Cook	x			
Anders J Davidson	x			
Stephanie N. Davis	x			
Mark Diebel	x			
Alexander L Eastman	x			
Scott C Fligor	x			
Brian L. Frank	x			
R. Stephen Smith and Sarah E Gray	x			
John A. Harvin	x			
Faisal Shah Jehan	x			
Bellal Joseph	x			
Erica D Kane	x			
Nikolas S. Kappy	x			
Charles A. Karcutskie	x			
Nathan W Kugler	x			
Anastasia Kunac	x			
Chris H. Lasecki	x			
Nathan R Manley	x			
Matthew Martin	x			
Patricia Martinez Quinones	x			
RICHARD S. MILLER	x			
Donald M Moe	x			
Hunter Burroughs Moore	x			
Vahagn C. Nikolian	x			
Michael Truitt	x			
Cassandra Lane Reynolds		Cook Medical	Educational research grant for this study	Grant Recipient
Ameila T. Rogers	x			

# DISCLOSURE INFORMATION

Morgan Schellenberg	x			
Leilani Schwarcz	x			
Steven R. Shackford	x			
John P Sharpe	x			
Desarom Teso	x			
Christine J. Waller	x			
Ben L. Zarzaur	x			

PLANNING COMMITTEE	NOTHING TO DISCLOSE	DISCLOSURE		
		COMPANY	ROLE	RECEIVED
Oscar Guillamondegui	x			
Eric Toschlog	x			
Kimberly Peck	x			
Mitch Cohen	x			
Ajai Malhotra	x			
Laura Moore		Decisio Health	Clinical Founder	Stock
Manny Lorenzo	x			
Soumitra Eachempati	x			
Rochelle Dicker	x			
Susan Rowell	x			
Carl Hauser	x			

# WTA MISSION STATEMENT

The Western Trauma Association is committed to the improvement of trauma care through research, education, sharing of clinical experiences, and the development of physicians of all specialties who are involved in the care of trauma patients. The goals of the Association are not only the intellectual growth attained through increased knowledge, but also the emotional growth attained through camaraderie and interaction with family and friends in an environment conducive to winter sports.

# 2016-2017 OFFICERS & COMMITTEE CHAIRS

## Officers

President	Carl J. Hauser, MD
President-Elect	Dennis W. Vane, MD
Vice President	Roxie M. Albrecht, MD
Secretary	David V. Shatz, MD
Treasurer	Robert McIntyre, MD
Historian	Mark Metzdorff, MD
Immediate Past President	Thomas M. Scalea, MD

## Board of Directors

David H. Livingston, MD	2017
Krista L. Kaups, MD	2017
R. Stephen Smith	2017
Christine S. Cocanour, MD	2018
Nick Namias, MD	2018
Brent King, MD	2018
Thomas M. Scalea, MD	2019
Carlos Brown, MD	2019
Enrique Ginzburg, MD	2019

## Term Ends

## Program Committee

Richard S. Miller, MD, *Chair*

## Publications Committee

Rochelle Dicker, MD, *Chair*

## Nominating Committee

Thomas M. Scalea, MD, *Chair*

## Multi-Center Trials Committee

Mitch Cohen, MD, *Chair*

## Algorithms Committee

Kenji Inaba, MD, *Chair*

# 2016-2017 COMMITTEES

## **Program Committee**

Richard S. Miller, MD, *Chair*  
Oscar Guillamondegui, MD  
Eric Toschlog, MD, *ex-officio*  
Kimberly Peck, MD  
Mitch Cohen, MD  
Ajai Malhotra, MD  
Laura Moore, MD  
Manny Lorenzo, MD  
Soumitra Eachempati, MD  
Susan Rowell, MD  
Rochelle Dicker, MD, *ex-officio*  
Carl Hauser, MD, *ex-officio*

## **Publications Committee**

Rochelle Dicker, MD, *Chair*  
Michel Aboutanos, MD  
Megan Brenner, MD  
Greg Campbell, MD  
Clay Cothren- Burlew, MD  
Marc De Moya, MD  
Alex Eastman, MD  
Lisa Ferrigno, MD  
Oliver Gunter, MD  
James McCarthy, MD  
Ashraf Mansour, MD  
Laura Moore, MD  
Nick Namias, MD  
Mark Shapiro, MD  
Jason Sperry, MD  
Rob Todd, MD  
Jennifer Watters, MD  
Ben Zarzaur, MD

## **Nominating Committee**

Thomas M. Scalea, MD, *Chair*  
Christine Cocanour, MD  
David H. Livingston, MD  
Nicholas Namias, MD  
Martin Schreiber, MD

## **Multi-Center Trials Committee**

Mitch Cohen, MD, *Chair*

## **Algorithms Committee**

Kenji Inaba, MD, *Chair*  
Hasan Alam, MD  
Karen Brasel, MD  
Carlos Brown, MD  
Mitch Cohen, MD  
Marc De Moya, MD  
Rochelle Dicker, MD, *ex-officio*  
Matt Martin, MD  
Gene Moore, MD, *ex-officio*  
Susan Rowell, MD  
David V. Shatz, MD, *ex-officio*  
Gary Vercrusse, MD



# WTA PRESIDENTS

Robert G. Volz, MD	1971	Vail
Robert G. Volz, MD	1972	Vail
Peter V. Teal, MD	1973	Vail
William R. Hamsa, MD	1974	Aspen
Arthur M. McGuire, MD	1975	Sun Valley
Lynn Ketchum, MD	1976	Snowmass
Fred C. Chang, MD	1977	Park City
Glen D. Nelson, MD	1978	Steamboat
Gerald D. Nelson, MD	1979	Snowmass
Kevin G. Ryan, MD	1980	Snowbird
David S. Bradford, MD	1981	Jackson Hole
Erick R. Ratzler, MD	1982	Vail
William R. Olsen, MD	1983	Jackson Hole
Earl G. Young, MD	1984	Steamboat Springs
Robert B. Rutherford, MD	1985	Snowbird
Rudolph A. Klassen, MD	1986	Sun Valley
Robert J. Neviasser, MD	1987	Jackson Hole
Robert C. Edmondson, MD	1988	Steamboat Springs
Ernest E. Moore, MD	1989	Snowbird
Stephen W. Carveth, MD	1990	Crested Butte
George E. Pierce, MD	1991	Jackson Hole
Peter Mucha, Jr., MD	1992	Steamboat
David V. Feliciano, MD	1993	Snowbird
R. Chris Wray, MD	1994	Crested Butte
David A. Kappel, MD	1995	Big Sky
Thomas H. Cogbill, MD	1996	Grand Targhee
G. Jerry Jurkovich, MD	1997	Snowbird
James B. Benjamin, MD	1998	Lake Louise
Herbert J. Thomas III, MD	1999	Crested Butte
Barry C. Esrig, MD	2000	Squaw Valley
Steven R. Shackford, MD	2001	Big Sky
James A. Edney, MD	2002	Whistler-Blackcomb
J. Scott Millikan, MD	2003	Snowbird
Harvey J. Sugerman, MD	2004	Steamboat Springs
Scott R. Petersen, MD	2005	Jackson Hole

# WTA PRESIDENTS

Harold F. Sherman, MD	2006	Big Sky
Frederick A. Moore, MD	2007	Steamboat Springs
James W. Davis, MD	2008	Squaw Valley
Grace S. Rozycki, MD	2009	Crested Butte
Robert C. Mackersie, MD	2010	Telluride
M. Gage Ochsner, MD	2011	Big Sky
R. Lawrence Reed, MD	2012	Vail
Mark T. Metzdorff, MD	2013	Snowmass
David H. Livingston, MD	2014	Steamboat Springs
Christine S. Cocanour, MD	2015	Telluride
Thomas M. Scalea, MD	2016	Squaw Valley
Carl J. Hauser, MD	2017	Snowbird

# NEW MEMBERS

## Western Trauma Association Welcomed the Following New Members at the 2016 Annual Meeting

### **Shana Ballow, MD**

Fresno, CA  
General Surgery  
Active Member

### **Matthew Eckert, MD**

Tacoma, WA  
Surgical Critical Care  
Active Member

### **Elan Jeremitsky, MD**

Springfield, IL  
General Surgery  
Active Member

### **Kwang Suh, MD**

Columbus, OH  
General Surgery/Surgical Critical Care  
Active Member

# WESTERN TRAUMA FOUNDATION DONORS

*Current lifetime accumulation status based on 2016 year end*

## **Summit (\$25,000 and up)**

Barry Esrig  
Thomas Scalea  
Robert Volz

## **Extreme (\$10,000-24,999)**

James Davis  
David Feliciano  
Grace Rozycki

## **Couloir Society (\$5,000 - \$9,999)**

Roxie Albrecht  
Christine Cocanour  
David Livingston  
Mark Metzdorff  
J. Scott Millikan  
Robert Neviasser  
Scott Petersen  
R. Lawrence Reed  
Steven Shackford  
Dennis Vane

## **Double Black Diamond Club (\$2,500 - \$4,999)**

John Adams  
Denis Bensard  
Marilu Bintz  
Kimberly Davis  
Soumitra Eachempati  
Enrique Ginzburg  
Carl Hauser  
David Kappel  
Krista Kaups  
David Kissinger  
Robert Mackersie  
Matthew Martin  
Robert McIntyre, Jr.  
Andrew Michaels  
Steven Ross  
R. Stephen Smith  
Harvey Sugerman  
Herbert Thomas, III

# WESTERN TRAUMA FOUNDATION DONORS

## **Black Diamond Circle**

**(\$1,000 - \$2,499)**

James Benjamin  
Walter Biffel  
Karen Brasel  
Megan Brenner  
Miriam Bullard  
Gregory Campbell  
David Ciesla  
Thomas Cogbill  
Raul Coimbra  
Marc de Moya  
Rochelle Dicker  
Doreen DiPasquale  
George Dulabon  
K. Dean Gubler  
Gregory Jurkovich  
Brent King  
M. Margaret Knudson  
Rosemary Kozar  
Guy Lanzi  
William Long  
Manuel Lorenzo  
Barbara Mainville  
James McCarthy  
John McGill  
Richard Miller  
Ernest Moore  
Frederick Moore  
Steve Moulton  
Nicholas Namias  
M. Gage Ochsner  
Patrick Offner  
Peter Rhee  
Anne Rizzo  
Martin Schreiber

David Shatz  
Harold Sherman  
Keith Stephenson  
Michael Truitt  
Steven Wald  
Jennifer Watters  
Michaela West

## **Blue Trail Associate**

**(\$500 - \$999)**

Hasan Alam  
Scott Armen  
Bonny Baron  
Carlos Brown  
Howard Champion  
Roy Cobean  
Mitch Cohen  
Alain Corcos  
Clay Cothren-Burlew  
James Cushman  
Bruce Ferris  
Richard Gamelli  
Larry Gentilello  
John Hall  
David Hoyt  
Riyad Karmy-Jones  
Alicia Mangram  
M. Ashraf Mansour  
Frank Nastanski  
David Notrica  
Kimberly Peck  
J. Bradley Pickhardt  
Basil Pruitt  
Susan Rowell  
Henry Sagi  
Aaron Scifres

# WESTERN TRAUMA FOUNDATION DONORS

## **Blue Trail Associate**

**(\$500 - \$999)** continued

Mark Shapiro

George Testerman

Brian Tibbs

S. Robb Todd

Eric A. Toschlog

R. Christie Wray, Jr.

## **Green Trail Associate**

**(up to \$499)**

Donald Carter

Charles Cook

Todd Costintini

Matthew Davis

Jody Digiacomio

Brian Eastridge

John Fildes

Alfonso Fonseca

Charles Fox

Warren Gall

Rajesh Gandhi

Rajan Gupta

Michael Hauty

James Hebert

Kenji Inaba

Jay Johannigman

Laura Johnson

Barbara Latenser

Richard Leone

Robert Letton

Heather MacNew

Charles Mains

Ajai Malhotra

Alan Marr

Robert Maxwell

Laura Moore

Charlene Nagy

Keith O'Malley

George Pierce

Edmund Rutherford

Jack Sava

Carol Schermer

Kevin Schuster

Aaron Scifres

Ricard Townsend

Daniel Vargo

Gary Verduyck

Amy Wyrzykowski

Ben Zarzaur

# IN MEMORIAM

**Earl G. Young, MD**

February 27, 1989

**Gerald S. Gussack, MD**

August 25, 1997

**Peter Mucha, Jr., MD**

August 9, 2006

**W. Bishop McGill, MD**

October 14, 2007

**Ronald P. Fischer, MD**

January 25, 2013

**M. Gage Ochsner, MD**

April 26, 2013

**George Cierny, MD**

June 24, 2013

**R. Christie Wray, MD**

November 18, 2013

**Robert B. Rutherford, MD**

November 22, 2013

**Doreen DiPasquale, MD**

January 7, 2014

**Barbara Latenser, MD**

June 15, 2015

**Matthew L Davis, MD**

September 3, 2015

# EARL YOUNG AWARD

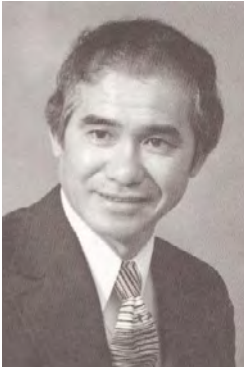

**Earl G. Young, MD  
(1928-1989)**

## **RESIDENT PAPER COMPETITION**

Dr. Earl G. Young of Minneapolis was a founding member of the Western Trauma Association and its 14<sup>th</sup> President. He died of a myocardial infarction, Monday, February 27, 1989, while skiing at Snowbird during the 19<sup>th</sup> Annual Meeting of the Association.

Dr. Young received his medical degree from the University of Rochester, N.Y. and Ph.D. in surgery from the University of Minnesota. He completed advanced training in cancer research at Harvard, a fellowship in cardiovascular surgery at Baylor University in Houston and studied microvascular surgery at the University of California-San Diego.

He was a clinical professor of surgery at the University of Minnesota Medical School, and a practicing general and vascular surgeon at the Park-Nicollet Clinic in Minneapolis from 1960. He was nationally known and was actively involved in research and education throughout his career. In 1988, one year before his untimely death, he received the Owen H. Wangensteen Award for Academic Excellence from the University of Minnesota Health Science Center. It was awarded by an unprecedented unanimous vote of all 72 surgical residents.

The Residents Paper competition was begun in 1991 as a tribute to Dr. Young's memory and his "spirit of inquiry, love of learning ... and commitment in service to mankind."\* The award is given to the best resident paper presented at the Annual Meeting.

*\*Dr. John Najarian characterizing Earl at a memorial service in his honor at the University of Minnesota.*



# EARL G. YOUNG AWARD RECIPIENTS

<b>Resident</b>	<b>Institution</b>	<b>Year</b>
Joseph Schmoker, MD	University of Vermont	1991
Joseph Schmoker, MD	University of Vermont	1992
Charles Mock, MD	University of Washington	1993
Gino Travisani, MD	University of Vermont	1994
Phillip C. Ridings, MD	Medical College of Virginia	1995
David Han, MD	Emory University	1996
Preston R. Miller, MD	Wake Forest University	1997
Geoffrey Manley, MD, PhD	University of California, San Francisco	1998
James M. Doty, MD	Medical College of Virginia	1999
David J. Ciesla, MD	Denver Health/University of Colorado	2000
Ricardo J. Gonzales, MD	Denver Health/University of Colorado	2001
Scott C. Brakenridge, MD	Cook County Hospital	2002
Adena J. Osband, MD	UMDNJ-New Jersey Medical School	2003
Cindy Lee, MD	UMDNJ-New Jersey Medical School	2004
Ernest A. Gonzalez, MD	University of Texas at Houston	2005
Jennifer M. Watters, MD	Oregon Health & Science University	2005
Jennifer J. Wan, MD	University of California, San Francisco	2006
Jennifer J. Wan, MD	University of California, San Francisco	2007
Keir J. Warner, MD	University of Washington	2008
T. W. Constantini, MD	University of California, San Diego	2009
C. Anne Morrison, MD	Baylor College of Medicine	2010
Marlin Causey, MD	Madigan Army Medical Center	2011
Phillip Letourneau, MD	University of Texas at Houston	2011
Gerard De Castro, MD	University of Maryland	2011
Matthew E. Kutcher, MD	University of California, San Francisco	2012
Kimberly Song, MD, MA	UMDNJ - New Jersey Medical School	2013
Lucy Kornblith, MD	UCSF/SFGH, San Francisco	2014
Hunter B. Moore, MD	Denver Health/University of Colorado	2015
George Black, MD	Madigan Army Medical Center	2016

# PRESIDENTIAL ADDRESS



## “RETURN TO SNOWBIRD”

Tuesday, March 7  
5:00 pm - 6:00 pm

### **Carl J. Hauser, MD, FACS**

Beth Israel Deaconess Medical Center  
Boston, MA

WTA President Carl Jeffrey Hauser went to medical school at New York University and was a surgical resident at Harbor/UCLA Medical Center in Los Angeles. At Harbor he met William C. Shoemaker, one of the inventors of Surgical Intensive Care. It was Dr. Shoemaker’s example that led Dr. Hauser down a road toward Trauma and Critical Care and taught him how to be a surgical scientist. After residency, Dr. Hauser became director of a trauma center in the fledgeling Los Angeles trauma system that lasted less than a year before running out of money. After that closure, Dr. Hauser spent a year attending part time at Los Angeles County/USC Trauma Center before moving to the

# PRESIDENTIAL ADDRESS

University of Mississippi Medical Center to join his friend Galen Poole. Generously supported there by chairman Bob Rhodes, Dr. Hauser was first able to establish a laboratory and begin to study the Immunology of Injury by investigating the generation of inflammatory cytokines by fracture hematomas. This paper, presented at the AAST, brought him to the attention of another WTA president-to-be, Dr. David Livingston. In 2006, Dr. Livingston recruited Dr. Hauser to the NJ State Trauma Center in Newark, where they worked together for 10 years, building Newark into one of the preeminent trauma centers in the country, with each becoming NIH R-01 funded in the process, and eventually bringing an NIH Program Project to their chairman, Ed Deitch. Along with Dr. Hauser's love of trauma he brought his love of skiing to Newark. So Dr. Livingston invited him to attend his first WTA meeting in 1997, right here at Snowbird. Subsequently, they made a pact that they would never hire another skier as faculty simply so that they could both go to the WTA.

Dr. Hauser became a WTA member in 2000, and has been to every meeting since 1997. In 2006 Dr. Hauser moved his laboratory to Boston although he readily admits he left his heart in Newark. But taking advantage of the scientific infrastructure of the Harvard system Dr. Hauser has been able to make his program into one of the most successful surgical laboratories in the country, producing key basic science advances and eventually succeeding in obtaining funding from the Department of Defense for his own program project, the HALO (Harvard-Longwood) consortium. This group of six nationally known trauma laboratories has united to study the molecular mechanisms by which tissue injury predisposes injured patients to infection. Of all his achievements however, Dr. Hauser is most proud of being elected to lead his adopted family of peers, the Western Trauma Association. So he is determined to make this "Return to Snowbird" an exciting and gratifying event for all his family.

## “PAINT THE CEILING” LECTURESHIP

In 1997, Dr. Gregory “Jerry” Jurkovich delivered his Presidential Address entitled “Paint the Ceiling: Reflections on Illness”. This was a personal account of his battle with non-Hodgkin’s lymphoma. His deep insights were shared from a patient’s perspective, even that of a stained ceiling that he observed while lying on his back. He proposed that future WTA Scientific Programs have some time “dedicated to our patients and to the Art of Medicine”.

<b>Presenter</b>	<b>Year</b>	<b>Location</b>
G. Jerry Jurkovich, MD	1997	Snowbird
John W. McGill, MD	1998	Lake Louise
William T. Close, MD	1999	Crested Butte
Jimmy Cornell	2000	Squaw Valley
Geoff Tabin, MD	2001	Big Sky
James H. “Red” Duke, MD	2002	Whistler
David V. Shatz, MD	2003	Snowbird
Susan and Tim Baker	2004	Steamboat Springs
Alex Habel, MD	2005	Jackson Hole
Andrew Schneider	2006	Big Sky
Ernest E. Moore, MD	2007	Steamboat Springs
Pamela Kallsen	2008	Squaw Valley
Sylvia Campbell, MD	2009	Crested Butte
William Schechter, MD	2010	Telluride
Jeff McKenney, MD	2011	Big Sky
Larry M. Gentilello, MD	2012	Vail
Neil L. Barg, MD	2013	Snowmass
Ziad Sifri, MD	2014	Steamboat Springs
Julie Freischlag, MD	2015	Telluride
Lewis Rubinson, MD, PhD	2016	Squaw Valley
Kenneth Waxman, MD, FACS	2017	Snowbird

## **PAINT THE CEILING LECTURE**



### **FROM THE OTHER SIDE: MY DAUGHTER, CANCER, AND ME**

Thursday, March 9  
5:15 pm – 6:00 pm

**Kenneth Waxman MD FACS**  
Santa Barbara, CA

Ken was born in San Francisco. He received his undergraduate degree from UC Berkeley, his MD from The University Of Chicago, and his surgical training at Harbor UCLA. Ken began his surgical career at Harbor, and then moved to UC Irvine where he became Professor of Surgery, and directed the trauma center, burn unit, and surgical ICU. He then moved to Santa Barbara Cottage Hospital to direct the surgical residency program, and create the first trauma center on California's central coast. Ken has published over 200 scientific papers, and a book, *Ajak's Song*, about his experience working as a surgeon in South Sudan with Doctors without Borders. He currently works as an international hospital surveyor, serves on the Board at the William Sansum Diabetes Research Institute, and directs a nonprofit organization supporting medical education for South Sudanese students.

# FOUNDERS' BASIC SCIENCE LECTURESHIP

Throughout the years, the Western Trauma Association has matured as an academic society while maintaining the cherished elements of friendship, collegiality and family. In honor of this unique spirit, a founding member has generously provided the idea and most of the financial support for an annual *Founders' Basic Science Lectureship*. The purpose of this Lecture is to further enhance the educational value of our Scientific Meeting relative to the area of basic science research. This Lecture reflects the vision and dedication of our founding members and will hold a prominent place in all future programs.

<b>Presenter</b>	<b>Year</b>	<b>Location</b>
Raul Coimbra, MD	2009	Crested Butte
Lawrence Diebel, MD	2010	Telluride
Carl J. Hauser, MD	2011	Big Sky
Fred Moore, MD	2012	Vail
Steve Shackford, MD	2013	Snowmass
Hasan B. Alam, MD	2014	Steamboat Springs
Charles S. Cox, Jr. MD	2015	Telluride
Rosemary Kozar, MD	2016	Squaw Valley
Mitchell J. Cohen, MD	2017	Snowbird

# FOUNDERS' BASIC SCIENCE LECTURE



## TRANSLATIONAL APPROACHES TO ACUTE TRAUMATIC COAGULOPATHY

Wednesday, March 8  
8:20 am - 9:00 am

**Mitchell J. Cohen, MD**  
University of Denver  
Denver, CO

Mitchell Cohen is the Bruce Rockwell Chair of Surgery at Denver Health Medical Center and Professor and Vice Chair of Surgery at the University of Colorado. Clinically he is an active Trauma, General and Acute Care Surgeon as well as a busy Intensivist. Dr. Cohen has an active NIH and DoD funded basic science research lab, which studies coagulation and inflammation perturbations after trauma. Specifically, his lab continues to examine the mechanisms of traumatic coagulopathy and mediators of protein C system activation after trauma. In addition to its basic science focus the Cohen research group transnationally studies similar topics through multiple clinical characterization and interventional trials aimed at elucidating the post trauma coagulation milieu and optimal resuscitation and treatment. Finally, the Cohen group has an active interest in in silico data and model driven approaches to modeling of biological and physiologic systems. In keeping with this his group has done extensive work on the use of Big Data towards improving personalized medicine and outcomes. His work includes multi scale modeling projects ranging from coagulation and endothelial biology to causal inference prediction of patient physiologic state and trajectory. His best job however is as Dad to Ava (10) and husband to Stephanie.

## NOTES



## SUNDAY, MARCH 5, 2017

---

5:00 pm - 7:00 pm

**Registration Open**

*Primrose Level C Foyer*

---

5:00 pm - 7:00 pm

**Welcome Reception**

*Primrose Level C*

---

5:00 pm - 7:00 pm

**Children's Reception**

*Wasatch Room*

---

6:30 pm - 7:00 pm

**Western Trauma Foundation Board Meeting (Invitation Only)**

*Board Room*

---

7:00 pm - 8:00 pm

**WTA Past Presidents' Meeting (Invitation Only)**

*Board Room*

---

# AGENDA

## MONDAY, MARCH 6, 2017

---

6:30 am - 9:30 am

### Registration & Exhibits Open

Cliff Lodge Ballroom Lobby

---

6:30 am - 8:00 am

### Attendee Breakfast

Cliff Lodge Ballroom Lobby

---

7:00 am - 9:00 am

### Scientific Session 1 - Earl Young Competition

Cliff Lodge Ballroom

**Moderator: Richard S. Miller, MD**

---

7:00 am -  
7:20 am

**1. SMARTPHONE-BASED MOBILE THERMAL IMAGING TECHNOLOGY TO ASSESS LIMB PERFUSION AND TOURNIQUET EFFECTIVENESS UNDER NORMAL AND BLACKOUT CONDITIONS**

*Morgan Barron, Tacoma, WA*

**Page  
41**

---

7:20 am -  
7:40 am

**2. VALPROIC ACID DECREASES BRAIN LESION SIZE AND IMPROVES NEUROLOGIC RECOVERY IN SWINE SUBJECTED TO TRAUMATIC BRAIN INJURY, HEMORRHAGIC SHOCK, AND POLYTRAUMA**

*Vahagn C. Nikolian, Ann Arbor, MI*

**Page  
43**

---

7:40 am -  
8:00 am

**3. THE TEMPORAL RESPONSE AND MECHANISM OF ACTION OF TRANEXAMIC ACID IN ENOTHELIAL GLYCOCAYLX DEGRADATION**

*Mark Diebel, Detroit, MI*

**Page  
45**

---

8:00 am -  
8:20 am

**4. BLUNT CEREBROVASCULAR INJURY SCREENING IN CHILDREN: ARE THEY JUST LITTLE ADULTS?**

*Mackenzie Cook, Seattle, WA*

**Page  
47**

---

8:20 am -  
8:40 am

**5. THREE VERSUS FOUR-FACTOR PROTHROMBIN COMPLEX CONCENTRATES FOR FACTOR-BASED RESUSCITATION IN A PORCINE HEMORRHAGIC SHOCK MODEL**

*Donald M Moe, Tacoma, WA*

**Page  
49**

---

8:40 am -  
9:00 am

**6. FIBRINOLYSIS SHUTDOWN IS ASSOCIATED WITH A FIVE-FOLD INCREASE IN MORTALTY IN TRAUMA PATIENTS LACKING SENSITIVITY TO TISSUE PLASMINOGEN ACTIVATOR**

*Hunter Burroughs Moore, Denver, CO*

**Page  
51**

---

## MONDAY, MARCH 6, 2017

---

7:30 am - 9:00 am

**Friends & Family Breakfast (Open to Friends & Family registrants only, must present voucher)**

*Aerie Restaurant, Cliff Lodge*

---

12:00 pm - 1:30 pm

**Mountain Mentor Lunch (separate registration fee)**

*Seven Summits*

---

3:30 pm - 6:00 pm

**Registration & Exhibits Open**

*Cliff Lodge Ballroom Lobby*

---

4:00 pm - 6:00 pm

**Scientific Session 2 - Earl Young Competition**

*Cliff Lodge Ballroom*

**Moderator: Susan Rowell, MD**

---

4:00 pm - 4:20 pm	<b>7. COMPARISON OF DIRECT SITE ENDOVASCULAR REPAIR UTILIZING EXPANDABLE PTFE STENT GRAFTS VS. STANDARD VASCULAR SHUNTS IN A PORCINE (SUS SCROFA) MODEL</b>  Anders J Davidson, Sacramento, CA	<b>Page 53</b>
----------------------	------------------------------------------------------------------------------------------------------------------------------------------------------------------------------------------------------	--------------------

---

4:20 pm - 4:40 pm	<b>8. THORACIC IRRIGATION PREVENTS RETAINED HEMOTHORAX: A PROSPECTIVE PROPENSITY SCORE MATCHED ANALYSIS</b>  Nathan W Kugler, Milwaukee, WI	<b>Page 55</b>
----------------------	---------------------------------------------------------------------------------------------------------------------------------------------------	--------------------

---

4:40 pm - 5:00 pm	<b>9. HUMAN NEUTROPHIL ELASTASE MEDIATES FIBRINOLYSIS SHUTDOWN THROUGH COMPETITIVE DEGRADATION OF PLASMINOGEN AND GENERATION OF ANGIOSTATIN</b>  Christopher D. Barrett, Cambridge, MA	<b>Page 57</b>
----------------------	----------------------------------------------------------------------------------------------------------------------------------------------------------------------------------------------	--------------------

---

5:00 pm - 5:20 pm	<b>10. EARLY CHEMICAL PROPHYLAXIS IS ASSOCIATED WITH DECREASED PULMONARY EMBOLISM WITHOUT CONCOMITANT INCREASE IN SPINAL CORD HEMATOMA EXPANSION AFTER TRAUMATIC SPINAL CORD INJURY</b>  Ronald Chang, Houston, TX	<b>Page 59</b>
----------------------	--------------------------------------------------------------------------------------------------------------------------------------------------------------------------------------------------------------------------	--------------------

---

# AGENDA

## MONDAY, MARCH 6, 2017

---

5:20 pm - 5:40 pm     **11. PERITONEAL CAVITY LAVAGE REDUCES THE PRESENCE OF MITOCHONDRIAL DAMAGE ASSOCIATED MOLECULAR PATTERNS IN OPEN ABDOMEN PATIENTS**     **Page 61**  
Patricia Martinez Quinones, Augusta, GA

---

5:40 pm - 6:00 pm     **12. GOOD NEWS, BAD NEWS: AN ANALYSIS OF 11,294 GUNSHOT WOUNDS OVER TWO DECADES IN A SINGLE CENTER**     **Page 63**  
Nathan R Manley, Memphis, TN

---

6:00 pm - 8:00 pm  
**WTA Board Meeting - by invitation only**  
*Wasatch B*

---

6:30 pm - 7:30 pm  
**Resident Reception - open to registered Residents**  
*Alpenglow Level 10*

---

6:30 pm - 8:30 pm  
**WTA Family Night**  
*Golden Cliff / Eagles Nest*

---

## TUESDAY, MARCH 7, 2017

---

6:30 am - 9:30 am

### Registration & Exhibits Open

Cliff Lodge Ballroom Lobby

---

6:30 am - 8:00 am

### Attendee Breakfast

Cliff Lodge Ballroom Lobby

---

7:00 am - 9:00 am

### Scientific Session 3

Cliff Lodge Ballroom

#### Moderator: Oscar Guillamondegui, MD

---

7:00 am - 7:20 am	<b>13. SURGICAL STABILIZATION OF RIB FRACTURES: INCREASING AT AN ALARMING RATE?</b> <i>Erica D Kane, Springfield, MA</i>	<b>Page 65</b>
----------------------	-----------------------------------------------------------------------------------------------------------------------------	--------------------

---

7:20 am - 7:50 am	PRO-CON: RIB FRACTURES: TO PLATE OR NOT- WHERE IS THE DATA? <i>Con: Oscar Guillamondegui Pro: Marc DeMoya</i>	<b>Page 67</b>
----------------------	----------------------------------------------------------------------------------------------------------------------	--------------------

---

7:50 am - 7:55 am	<b>14. THYROID STORM INDUCED BY TRAUMA: A CHALLENGING COMBINATION</b> <i>Stephanie N. Davis, Aurora, CO</i>	<b>Page 69</b>
----------------------	----------------------------------------------------------------------------------------------------------------	--------------------

---

7:55 am - 8:00 am	<b>15. HEMATOMAS IN TIGER TERRITORY: AN ENDOVASCULAR ALTERNATIVE TO WADING IN</b> <i>Desarom Teso, vancouver, WA</i>	<b>Page 71</b>
----------------------	-------------------------------------------------------------------------------------------------------------------------	--------------------

---

8:00 am - 8:20 am	<b>16. REBOA FOR THE IVC? RESUSCITATIVE BALLOON OCCLUSION OF THE INFERIOR VENA CAVA (REBOVC) TO ABATE MASSIVE HEMORRHAGE IN RETRO-HEPATIC VENA CAVA INJURIES</b> <i>Cassandra Lane Reynolds, Greenville, NC</i>	<b>Page 73</b>
----------------------	--------------------------------------------------------------------------------------------------------------------------------------------------------------------------------------------------------------------	--------------------

---

8:20 am - 8:40 am	<b>17. CONTEMPORARY MANAGEMENT OF SUBCLAVIAN AND AXILLARY ARTERY INJURIES - A WESTERN TRAUMA ASSOCIATION MULTICENTER REVIEW</b> <i>Christine J. Waller, La Crosse, WI</i>	<b>Page 75</b>
----------------------	------------------------------------------------------------------------------------------------------------------------------------------------------------------------------	--------------------

---

8:40 am - 9:00 am	<b>18. SELECTIVE USE OF PERICARDIAL WINDOW AND DRAINAGE AS SOLE TREATMENT FOR HEMOPERICARDIUM FROM PENETRATING CHEST TRAUMA</b> <i>Paul J. Chestovich, Las Vegas, NV</i>	<b>Page 77</b>
----------------------	-----------------------------------------------------------------------------------------------------------------------------------------------------------------------------	--------------------

---

# AGENDA

## TUESDAY, MARCH 7, 2017

---

7:30 am - 9:00 am

**Friends & Family Breakfast (Open to Friends & Family registrants only, must present voucher)**

*Aerie Restaurant, Cliff Lodge*

---

3:30 pm - 6:00 pm

**Registration & Exhibits Open**

*Cliff Lodge Ballroom Lobby*

---

4:00 pm - 6:00 pm

**Scientific Session 4**

*Cliff Lodge Ballroom*

**Moderator: Ajai Malhotra, MD**

---

4:00 pm -  
4:20 pm

**19. CERVICAL SPINE EVALUATION AND CLEARANCE IN THE INTOXICATED PATIENT: A PROSPECTIVE WTA MULTI-INSTITUTIONAL TRIAL AND SURVEY**

**Page  
79**

*Matthew Martin, Portland, OR*

---

4:20 pm -  
4:40 pm

**20. DON'T CALL ME CRAZY! DELIRIUM OCCURS OUTSIDE OF THE ICU**

**Page  
81**

*Michael Truitt, Dallas, TX*

---

4:40 pm -  
4:50 pm

**21. IN AN INSTANT: HOW AN ACT OF GUN VIOLENCE NEARLY TORE OUR FAMILIES APART**

**Page  
83**

*Alexander L Eastman, Dallas, TX*

---

4:50 pm -  
5:00 pm

**22. SEVEN DECADES OF SKIING-A TALE OF TWO BROTHERS**

**Page  
85**

*Christopher C. Baker, Caswell Beach, NC*

---

5:00 pm -  
6:00 pm

PRESIDENTIAL ADDRESS - OWNERSHIP

**Page  
87**

*Carl J. Hauser, MD, FACS, Boston, MA*

---

6:00 pm - 7:00 pm

**WTA Multicenter Trials Meeting**

*Cliff Lodge Ballroom*

---

## WEDNESDAY, MARCH 8, 2017

---

6:30 am - 9:30 am

### Registration & Exhibits Open

Cliff Lodge Ballroom Lobby

---

6:30 am - 8:00 am

### Attendee Breakfast

Cliff Lodge Ballroom Lobby

---

7:00 am - 9:00 am

### Scientific Session 5

Cliff Lodge Ballroom

**Moderator: Eric Toschlog, MD**

---

7:00 am - 7:20 am	<b>23. VENOUS THROMBOEMBOLISM AFTER MAJOR VENOUS INJURIES: COMPETING PRIORITIES</b>	<b>Page 89</b>
----------------------	-------------------------------------------------------------------------------------	--------------------

*Brian L. Frank, Scranton, PA*

---

7:20 am - 7:40 am	<b>24. IMPACT OF VENOUS THROMBOEMBOLISM CHEMOPROPHYLAXIS ON POSTOPERATIVE HEMORRHAGE FOLLOWING OPERATIVE STABILIZATION OF SPINE FRACTURES</b>	<b>Page 91</b>
----------------------	-----------------------------------------------------------------------------------------------------------------------------------------------	--------------------

*John P Sharpe, Memphis, TN*

---

7:40 am - 8:00 am	<b>25. OPTIMAL ANTIFACTOR-XA LEVELS FOR VENOUS THROMBOPROPHYLAXIS AFTER TRAUMA: A PRELIMINARY STUDY</b>	<b>Page 93</b>
----------------------	---------------------------------------------------------------------------------------------------------	--------------------

*Charles A. Karcutskie, Miami, FL*

---

8:00 am - 8:20 am	<b>26. PARATHYROID HORMONE AS A MARKER OF HYPOPERFUSION IN TRAUMA</b>	<b>Page 95</b>
----------------------	-----------------------------------------------------------------------	--------------------

*Scott C Fligor, Roanoke, VA*

---

8:20 am - 9:00 am	<b>BASIC SCIENCE LECTURE: TRANSLATIONAL APPROACHES TO ACUTE TRAUMATIC COAGULOPATHY</b>	<b>Page 97</b>
----------------------	----------------------------------------------------------------------------------------	--------------------

*Mitch Cohen, Denver, CO*

---

# AGENDA

## WEDNESDAY, MARCH 8, 2017

---

7:30 am - 9:00 am

**Friends & Family Breakfast (Open to Friends & Family registrants only, must present voucher)**

*Aerie Restaurant, Cliff Lodge*

---

10:00 am - 12:00 pm

**NASTAR Race (Sign-up by Tuesday morning at Registration Desk)**

*Mountain*

---

12:00 pm - 1:30 pm

**Mountain Picnic**

*Gad Valley*

---

3:30 pm - 6:00 pm

**Registration & Exhibits Open**

*Cliff Lodge Ballroom Lobby*

---

4:00 pm - 6:00 pm

**Book Club**

*Golden Cliff / Eagle's Nest*

---



## WEDNESDAY, MARCH 8, 2017

---

4:00 pm - 5:00 pm

### Scientific Session 6

Cliff Lodge Ballroom

**Moderator: Richard Miller, MD**

---

4:00 pm - 4:20 pm	<b>27. TEVAR IS THE NEW STANDARD FOR OPERATIVE MANAGEMENT OF BLUNT THORACIC AORTIC INJURY: A WESTERN TRAUMA ASSOCIATION MULTI-CENTER STUDY</b> <i>Steven R. Shackford, San Diego, CA</i>	<b>Page 99</b>
----------------------	---------------------------------------------------------------------------------------------------------------------------------------------------------------------------------------------	--------------------

---

4:20 pm - 4:25 pm	<b>28. COMPLETE ABDOMINAL VISCERAL ISCHEMIA IN A WOMAN WITH CHRONIC METHAMPHETAMINE ABUSE WHO SUSTAINED MULTIPLE STAB WOUNDS</b> <i>Jamie Anderson, Sacramento, CA</i>	<b>Page 101</b>
----------------------	---------------------------------------------------------------------------------------------------------------------------------------------------------------------------	---------------------

---

4:25 pm - 4:30 pm	<b>29. ACUTE AORTIC DISSECTION DUE TO SPINAL CORD PERFUSION PROTOCOL FOR BLUNT TRAUMATIC CORD INJURY: A CASE REPORT</b> <i>R. Stephen Smith and Sarah E Gray, Gainesville, FL</i>	<b>Page 103</b>
----------------------	--------------------------------------------------------------------------------------------------------------------------------------------------------------------------------------	---------------------

---

4:30 pm - 4:45 pm	ALGORITHM 1 - ABDOMINAL STAB WOUNDS <i>Matthew Martin</i>	<b>Page 105</b>
----------------------	--------------------------------------------------------------	---------------------

---

4:45 pm - 5:00 pm	ALGORITHM 2 - REBOA <i>Kenji Inaba</i>	<b>Page 107</b>
----------------------	-------------------------------------------	---------------------

---

5:00 pm - 6:30 pm

### Business Meeting (WTA Members Only)

Cliff Lodge Ballroom

---

## THURSDAY, MARCH 9, 2017

---

6:30 am - 9:30 am

### Registration & Exhibits Open

Cliff Lodge Ballroom Lobby

---

6:30 am - 8:00 am

### Attendee Breakfast

Cliff Lodge Ballroom Lobby

---

7:00 am - 9:00 am

### Scientific Session 7

Cliff Lodge Ballroom

**Moderator: Mitch Cohen, MD**

---

7:00 am - 7:20 am	<b>30.</b> REMOTE ISCHEMIC CONDITIONING PRESERVES COGNITION AND MOTOR COORDINATION IN A MOUSE MODEL OF TRAUMATIC BRAIN INJURY <i>Bellal Joseph, Tucson, AZ</i>	<b>Page 109</b>
----------------------	-------------------------------------------------------------------------------------------------------------------------------------------------------------------	---------------------

---

7:20 am - 7:40 am	<b>31.</b> DECOMPRESSIVE CRANIECTOMY VS. CRANIOTOMY ONLY FOR INTRACRANIAL HEMORRHAGE EVACUATION: A PROPENSITY MATCHED STUDY <i>Faisal Shah Jehan, Tucson, AZ</i>	<b>Page 111</b>
----------------------	---------------------------------------------------------------------------------------------------------------------------------------------------------------------	---------------------

---

7:40 am - 7:45 am	<b>32.</b> WHEN YOUR MIND IS BLOWN: MULTIDISCIPLINARY MANAGEMENT OF AN UNDETONATED INTRACRANIAL EXPLOSIVE <i>Richard D. Betzold, Nashville, TN</i>	<b>Page 113</b>
----------------------	-------------------------------------------------------------------------------------------------------------------------------------------------------	---------------------

---

7:45 am - 8:30 am	PRO-CON- I'M NOT DEAD YET: INITIAL EVALUATION OF TBI INJURY. CAN YOU DETERMINE SURVIVABILITY? <i>Pro: Susan Rowell, MD and Con: Raminder Nirula, MD</i>	<b>Page 115</b>
----------------------	------------------------------------------------------------------------------------------------------------------------------------------------------------	---------------------

---

8:30 am - 8:45 am	ALGORITHM 3 - RENAL <i>Carlos Brown</i>	<b>Page 117</b>
----------------------	--------------------------------------------	---------------------

---

8:45 am - 9:00 am	ALGORITHM 4 - BURNS <i>Gary Vercruyse</i>	<b>Page 119</b>
----------------------	----------------------------------------------	---------------------

---

3:30 pm - 6:00 pm

### Registration & Exhibits Open

Cliff Lodge Ballroom Lobby

---

## THURSDAY, MARCH 9, 2017

---

4:00 pm - 6:00 pm

### Scientific Session 8

Cliff Lodge Ballroom

**Moderator: Laura Moore, MD**

---

4:00 pm - 4:40 pm	PANEL OF EXPERTS: THE CLASH OF GENERATIONS: WHO'S WAY IS BEST IN THE APPROACH TO COMMON TRAUMA PROBLEMS  <i>Moderator: Kenji Inaba</i> <i>"Older Generation"- Tom Scalea, Jerry Jurkovich and Christine Coconour</i> <i>"Younger Generation"- Alex Eastman, Oliver Gunter and Laura Moore</i>	<b>Page</b> <b>121</b>
----------------------	-----------------------------------------------------------------------------------------------------------------------------------------------------------------------------------------------------------------------------------------------------------------------------------------------------------	---------------------------

---

4:40 pm - 5:00 pm	<b>33. BIG CHILDREN OR LITTLE ADULTS? A STATEWIDE ANALYSIS OF ADOLESCENT SEVERE POLYTRAUMA OUTCOMES AT PEDIATRIC VERSUS ADULT TRAUMA CENTERS</b>  <i>Frederick B. Rogers, Lancaster, PA</i>	<b>Page</b> <b>123</b>
----------------------	---------------------------------------------------------------------------------------------------------------------------------------------------------------------------------------------------	---------------------------

---

5:00 pm - 5:15 pm	<b>34. FAMILY ABSTRACT: SAVING LIVES OUTSIDE THE HOSPITAL: A FAMILY AFFAIR</b>  <i>Richard S. Miller, Nashville, TN</i>	<b>Page</b> <b>125</b>
----------------------	-------------------------------------------------------------------------------------------------------------------------------	---------------------------

---

5:15 pm - 6:00 pm	PAINT THE CEILING LECTURE: FROM THE OTHER SIDE: MY DAUGHTER, CANCER AND ME  <i>Kenneth Waxman, MD, FACS, Santa Barbara, CA</i>	<b>Page</b> <b>127</b>
----------------------	--------------------------------------------------------------------------------------------------------------------------------------	---------------------------

---

7:00 pm - 10:00 pm

### Children's Party

Camp Snowbird

---

6:30 pm - 7:30 pm

### Reception

Cliff Lodge Ballroom Lobby

---

7:30pm - 10:30pm

### Banquet

Cliff Lodge Ballroom

---

# AGENDA

---

## FRIDAY, MARCH 10, 2017

---

6:30 am - 9:30 am

### Registration & Exhibits Open

Cliff Lodge Ballroom Lobby

---

6:30 am - 8:00 am

### Attendee Breakfast

Cliff Lodge Ballroom Lobby

---

7:00 am - 9:00 am

### Scientific Session 9

Cliff Lodge Ballroom

**Moderator: Kimberly Peck, MD**

---

7:00 am - 7:20 am	<b>35.</b> THE NATURAL HISTORY OF SPLENIC VASCULAR ABNORMALITIES AFTER BLUNT INJURY: A WESTERN TRAUMA ASSOCIATION MULTICENTER TRIAL <i>Ben L. Zarzaur, Indianapolis, IN</i>	<b>Page 129</b>
----------------------	--------------------------------------------------------------------------------------------------------------------------------------------------------------------------------------	---------------------

---

7:20 am - 7:40 am	<b>36.</b> STRESS ULCER PROPHYLAXIS IS NOT NECESSARY IN THE CRITICALLY ILL TRAUMA PATIENT <i>Anastasia Kunac, Newark, NJ</i>	<b>Page 131</b>
----------------------	------------------------------------------------------------------------------------------------------------------------------------	---------------------

---

7:40 am - 8:00 am	<b>37.</b> IMPROVED OUTCOMES IN ELDERLY TRAUMA PATIENTS WITH THE IMPLEMENTATION OF TWO INNOVATIVE GERIATRIC-SPECIFIC PROTOCOLS <i>Eric H. Bradburn, Lancaster, PA</i>	<b>Page 133</b>
----------------------	--------------------------------------------------------------------------------------------------------------------------------------------------------------------------------	---------------------

---

8:00 am - 8:20 am	<b>38.</b> MORTALITY FOLLOWING EMERGENT TRAUMA LAPAROTOMY: A MULTICENTER, RETROSPECTIVE STUDY <i>John A. Harvin, Houston, TX</i>	<b>Page 135</b>
----------------------	----------------------------------------------------------------------------------------------------------------------------------------	---------------------

---

8:20 am - 9:00 am	PANEL OF EXPERTS: CASE RECORDS OF THE JOINT TRAUMA SYSTEMS: A WTA EXPERT PANEL <i>Moderators- Matthew Martin and Jennifer Gurney Panel: Carlos Brown, Deb Stein, Matt Eckert and Jim Davis</i>	<b>Page 137</b>
----------------------	----------------------------------------------------------------------------------------------------------------------------------------------------------------------------------------------------------	---------------------

---

3:30 pm - 6:00 pm

### Registration & Exhibits Open

Cliff Lodge Ballroom Lobby

---

## FRIDAY, MARCH 10, 2017

4:00 pm - 6:00 pm

### Scientific Session 10

Cliff Lodge Ballroom

**Moderator: Manuel Lorenzo, MD**

4:00 pm - 4:20 pm	<b>39.</b> HUMAN ADIPOSE-DERIVED STEM CELL TREATMENT MODULATES CELLULAR PROTECTION IN A TRAUMATIC BRAIN INJURY RAT MODEL <i>Nikolas S. Kappy, Camden, NJ</i>	<b>Page 139</b>
4:20 pm - 4:40 pm	<b>40.</b> MONOCYTE L-SELECTIN EXPRESSION AS AN EARLY BIOMARKER FOR POST-INJURY SEPSIS <i>Gabrielle Briggs, Newcastle, NSW</i>	<b>Page 141</b>
4:40 pm - 5:00 pm	<b>41.</b> INJURIES SUSTAINED DURING CONTACT WITH LAW ENFORCEMENT IN THE UNITED STATES: A NATIONAL TRAUMA DATA BANK STUDY <i>Morgan Schellenberg, Los Angeles, CA</i>	<b>Page 143</b>
5:00 pm - 5:20 pm	<b>42.</b> GEOSPATIAL MAPPING CAN BE USED TO IDENTIFY GEOGRAPHIC AREAS AND SOCIAL FACTORS ASSOCIATED WITH INTENTIONAL INJURY AS TARGETS FOR PREVENTION EFFORTS DISTINCT TO A GIVEN COMMUNITY <i>Chris H. Lasecki, Mobile, AL</i>	<b>Page 145</b>
5:20 pm - 5:40 pm	<b>43.</b> FINDING THE SIGNAL IN THE NOISE: COULD SOCIAL MEDIA BE UTILIZED FOR EARLY HOSPITAL NOTIFICATION OF MULTIPLE CASUALTY EVENTS? <i>Rachael A Callcut, San Francisco, CA</i>	<b>Page 147</b>
5:40 pm - 6:00 pm	<b>44.</b> TRAFFIC-RELATED INJURIES- DIRECT MEDICAL COSTS OF TRAUMA-ACTIVATED INJURIES IN SAN FRANCISCO, 2012-2014 <i>Leilani Schwarcz, San Francisco, CA</i>	<b>Page 149</b>

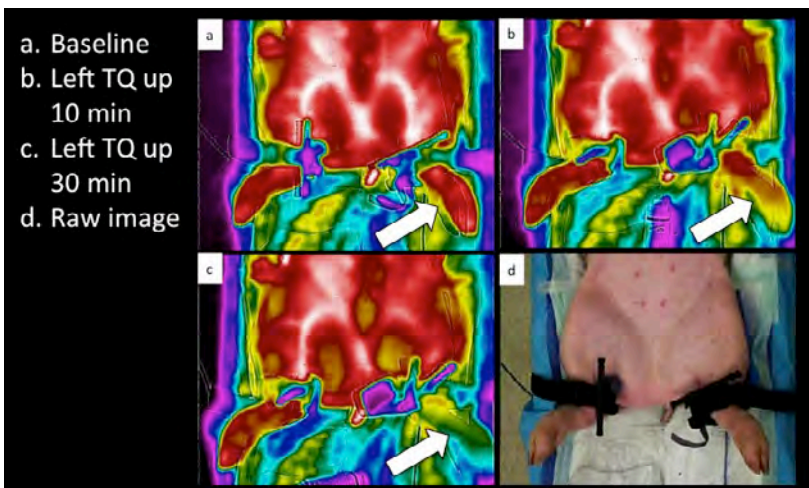

## NOTES

**Paper# 1 – EARL YOUNG COMPETITION**  
**Monday, 3/6/2017**

**SMARTPHONE-BASED MOBILE THERMAL IMAGING TECHNOLOGY TO ASSESS LIMB PERFUSION AND TOURNIQUET EFFECTIVENESS UNDER NORMAL AND BLACKOUT CONDITIONS**

MR Barron, JP Kuckelman, JM McClellan, MJ Derickson, CJ Phillips, MJ Eckert, MJ Martin  
Madigan Army Medical Center, Tacoma, WA

**Presenter: Morgan Barron**  
**Senior Sponsor: Matt Martin**

**INTRODUCTION:** Over the past decade there has been a resurgence of tourniquet (TQ) use in civilian and military settings. Several key challenges include assessment of limb perfusion and adequacy of TQ placement, particularly in the austere or pre-hospital environments. We investigated the utility of a novel smartphone-based forward-looking infrared (FLIR) system.

**METHODS:** A commercially available device (FLIR One, FLIR Systems, Inc.) that converts standard smartphones to a highly sensitive infrared thermal imager was utilized. Ten swine underwent tourniquet placement with no associated hemorrhage (NH) or with 40% hemorrhage (H). Static images were taken at 0, 5, 10, 20, and 30-minutes in 3 experiments. Experiment 1 simulated proper TQ application and experiment 2 had one TQ inadequately tightened. Experiment 3 simulated blackout combat conditions. FLIR temperatures, images, hemodynamics, and labs were collected. FLIR images were also presented to blinded observers who scored limb perfusion and adequacy of TQ placement.

**RESULTS:** The mean core temperature and MAP was 38.1°C and 62 mmHg in NH animals versus 38.2°C and 47 mmHg in H animals. H animals were more hypotensive ( $p=0.01$ ), anemic (HCT 14 vs 20,  $p=0.02$ ), tachycardic (126 bpm vs 101,  $p=0.04$ ), and vasodilated (SVR 641 vs 1004,  $p=0.008$ ), than NH animals. The FLIR temperature reading decreased significantly following proper TQ placement in all animals, with no difference between H and NH groups ( $\Delta_{Temp}$  9.8±4°C vs 10.8±2°C;  $p=0.7$ ). Qualitative FLIR image analysis showed clearly visible perfusion differences in all animals between baseline, adequate TQ, and inadequate TQ in both H and NH groups (Figure). The vast majority of blinded evaluators (n=29) correctly identified adequate and inadequate TQ placement at the 5-minute (98% correct) and 10-minute (99% correct) time points. Images in blackout combat-simulation conditions showed no adverse impact on thermal measurements, thermal changes with TQ placement, or in the ability to accurately characterize perfusion and TQ adequacy.

**CONCLUSIONS:** A simple, handheld, smartphone-based FLIR device demonstrated a high degree of accuracy, reliability, and ease of use for assessing limb perfusion. FLIR also allowed for rapid and reliable identification of adequate TQ placement that was not affected by co-existing major hemorrhage or blackout conditions.

# MRI Lesion Size

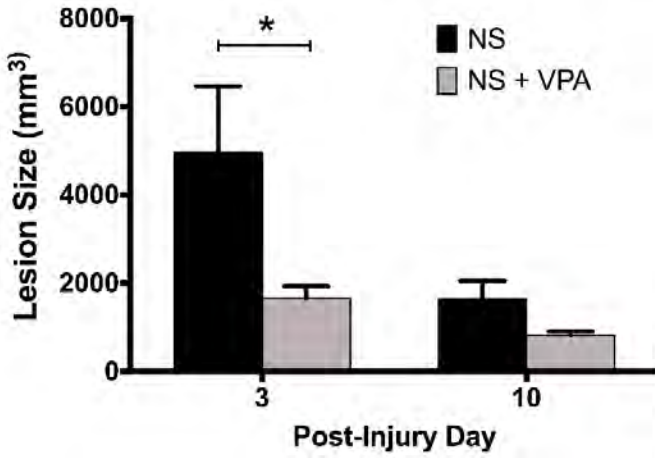

NOTES



**VALPROIC ACID DECREASES BRAIN LESION SIZE AND IMPROVES NEUROLOGIC RECOVERY IN SWINE SUBJECTED TO TRAUMATIC BRAIN INJURY, HEMORRHAGIC SHOCK, AND POLYTRAUMA**

VC Nikolian, PE Georgoff, P Chang, IS Dennahy, K Chtraklin, H Eidy,  
M Rasmussen, B Liu, Y Li, HB Alam  
University of Michigan Health System, Ann Arbor, MI

**Presenter: Vahagn C. Nikolian**  
**Senior Sponsor: Hasan Alam**

**INTRODUCTION:** We have previously shown that treatment with valproic acid (VPA) decreases brain lesion size in swine models of traumatic brain injury (TBI) and controlled hemorrhage. To translate this treatment into clinical practice, validation of drug efficacy and evaluation of pharmacologic properties in clinically realistic models of injury are necessary. In this study, we evaluate neurologic outcomes and perform pharmacokinetic analysis of a single dose of VPA in swine subjected to TBI, hemorrhagic shock, and visceral hemorrhage.

**METHODS:** Yorkshire swine (n= 5/cohort) were subjected to TBI, hemorrhagic shock, and polytrauma (liver and spleen injury, rib fracture, rectus abdominis crush). Animals remained in hypovolemic shock for two hours before resuscitation with normal saline (NS, volume = 3X hemorrhage) or NS+VPA (150 mg/kg). Neurologic severity scores were assessed daily for 30 days and brain lesion size was measured via magnetic resonance imaging on post-injury days (PID) 3 and 10. Serum samples were collected for pharmacokinetic analysis.

**RESULTS:** Shock severity and response to resuscitation were similar in both groups. VPA-treated animals demonstrated significantly less neurological impairment between PID 1-5 and smaller brain lesions on PID 3 (mean lesion size  $\pm$  SEM, mm<sup>3</sup>: NS = 4956 $\pm$ 1511 vs. NS+VPA = 828 $\pm$ 279, p = 0.047). Animals treated with VPA had faster neurocognitive recovery (days to initiation of testing, mean  $\pm$  SD: NS = 6.2 $\pm$ 1.6 vs. NS+VPA = 3.6 $\pm$ 1.5, p = 0.002; days to task mastery: NS = 7.0 $\pm$ 1.0 vs. NS+VPA = 4.8 $\pm$ 0.5, p = 0.03). The mean  $\pm$  SD maximum VPA concentrations, AUC, and half-life were 145 $\pm$ 38.2mg/L, 616 $\pm$ 150h $\square$ mg/L, and 1.70 $\pm$ 0.12h.

**CONCLUSIONS:** In swine subjected to TBI, hemorrhagic shock, and polytrauma, VPA treatment is safe, decreases brain lesion size, and reduces neurologic injury when compared to resuscitation with NS alone. These benefits are achieved at clinically translatable serum concentrations of VPA.

Mean  $\pm$  S.D.; N = 4 for each group

	Syndecan (ng/ml)	HLA (ng/ml)	ADAM-17 activity (RFU/ $\mu$ g protein)	MMP activity (RFU/min)
HUVEC alone	23.6 $\pm$ 1.4	15.4 $\pm$ 3.1	1.68 $\pm$ 0.3	40.5 $\pm$ 9.2
HUVEC + H <sub>2</sub> O <sub>2</sub>	46.3 $\pm$ 3.2*	46.9 $\pm$ 4.3*	5.38 $\pm$ 1.1*	168.3 $\pm$ 12.4*
HUVEC + epi	41.8 $\pm$ 4.1*	37.2 $\pm$ 5.2*	3.64 $\pm$ 0.6*	96.5 $\pm$ 10.8*
HUVEC+H <sub>2</sub> O <sub>2</sub> +epi	76.4 $\pm$ 6.8*	70.4 $\pm$ 7.6*	5.79 $\pm$ 0.9*	202.6 $\pm$ 19.1*
HUVEC + epi+ H <sub>2</sub> O <sub>2</sub> +TXA(30)	28.9 $\pm$ 2.2	20.9 $\pm$ 2.2	1.95 $\pm$ 0.5	58.1 $\pm$ 11.3
HUVEC + epi+ H <sub>2</sub> O <sub>2</sub> +TXA(1hr delay)	71.3 $\pm$ 7.3*#	63.3 $\pm$ 8.1*#	4.48 $\pm$ 1.2*#	148.9 $\pm$ 15.7*#

\*p<0.001 vs. HUVEC alone, #p<0.001 vs. TXA (30)

## NOTES

**Paper# 3 – EARL YOUNG COMPETITION**  
**Monday, 3/6/2017**

**THE TEMPORAL RESPONSE AND MECHANISM OF ACTION OF  
TRANEXAMIC ACID IN ENOTHELIAL GLYCOCAYLX DEGRADATION**

M Diebel, J Martin, D Liberati, L Diebel

Wayne State University Department of Surgery, Detroit, MI

**Presenter: Mark Diebel**

**Senior Sponsor: Lawrence Diebel**

**INTRODUCTION:** The endothelial glycocalyx (GCX) plays an important role in vascular barrier function. Damage to the GCX occurs due to a variety of causes including hypoxia, ischemia-reperfusion, stress related sympatho-adrenal activation, and inflammation. Tranexamic acid (TXA) when used as a part of a massive transfusion protocol may prevent GCX degradation. The therapeutic window for TXA administration and the mechanism of action has been under review. Membrane-anchored proteases (sheddases) are key components in endothelial cell biology including the regulation of vascular permeability. The effect of TXA administration on stress related GCX damage and the role of sheddases in this process was studied in a cell-based model.

**METHODS:** Confluent cultures of human umbilical vein endothelial cells (HUVEC) were exposed to 100  $\mu\text{M}$  hydrogen peroxide ( $\text{H}_2\text{O}_2$ ) and/or 10-3  $\mu\text{M}$  epinephrine (EPI) to stimulate post shock reperfusion. TXA (150  $\mu\text{M}$ ) was added 15, 60, or 120 minutes after  $\text{H}_2\text{O}_2$  and/or EPI exposure. GCX degradation was indexed by syndecan-1 and hyaluronic acid release. Activation of endothelial sheddases was indexed by ADAM-17 and MMP-9 activity in culture supernanents.

**RESULTS:** See JPEG

**CONCLUSIONS:** TXA as a serine protease inhibitor prevented GCX degradation via inhibition of endothelial sheddase activation. This effect was not apparent when TXA was administered >60 minutes after  $\hat{\sim}$ simulated $\hat{\sim}$ ™ reperfusion. Our study supports the clinical practice of early TXA administration in the severely injured patient.

**NOTES**

**Paper# 4 - EARL YOUNG COMPETITION**  
**Monday, 3/6/2017**

**BLUNT CEREBROVASCULAR INJURY SCREENING IN CHILDREN:  
ARE THEY JUST LITTLE ADULTS?**

M Cook, C Witt, R Bonow, E Bulger, S Arbabi, B Robinson and J Cuschieri  
Harborview Medical Center, Seattle, WA

**Presenter: Mackenzie Cook**  
**Senior Sponsor: Riyad Karmy-Jones**

**INTRODUCTION:** The rarity and nonspecific predictors of blunt cerebrovascular injuries (BCVI) continue to challenge trauma providers to design optimal screening criteria. Radiation concerns magnify these issues in children. The Eastern Association for the Surgery of Trauma (EAST) criteria, the Utah score (US) and the Denver criteria (DC) have been advocated as pediatric BCVI screening tools, though direct comparison is lacking. We hypothesized that current screening guidelines inaccurately identify pediatric patients with BCVI.

**METHODS:** This was a retrospective study of pediatric trauma patients ( $\leq 18$  years) treated at a single Level I trauma center from 2005-2015 with BCVI confirmed on CT or MR angiogram. Patients surviving  $<24$  hours were excluded. The primary outcome was missed injury, defined as a patient with a BCVI when screening triggers were not met. Fischer's exact and Mann-Whitney U tests were used.

**RESULTS:** We identified 7440 blunt pediatric trauma admissions of which 96 patients (1.3%) had 128 BCVIs. Median age was 16 (13,17) years, 59% were male and 60% were injured in motor vehicle crashes. A cervical-spine fracture was present in 41%. There were 83 carotid injuries, of which 73% were Biffel grade I or II and 45 vertebral injuries, of which 76% were Biffel grade I or II,  $p=0.8$ . More than 1 vessel was injured in 28% of patients.

A cerebrovascular accident (CVA) occurred in 18%; 8 identified on admission and 9 occurred thereafter. Aspirin was used in 59% of patients with BCVI; however the in-hospital CVA incidence was similar in those with and without use (11% vs. 9%,  $p=0.9$ ). EAST screening missed injuries in 17% of patients, US missed 36%, and DC missed 4%, significantly fewer than either EAST or US,  $p<0.01$ .

**CONCLUSIONS:** While less common than in adults, BCVI does occur in pediatric patients and a significant proportion develop a CVA, many of which are identified on admission. Although diagnosis of BCVI remains problematic, this is the first study to demonstrate that liberal screening of children using the DC appears to be associated with the lowest rate of missed injuries. This provides an opportunity for early therapeutic interventions to reduce CVA risk.

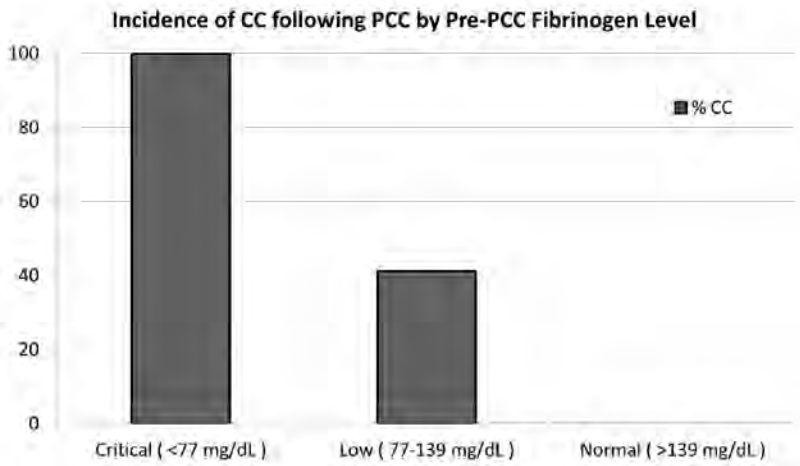

## NOTES

**Paper# 5 - EARL YOUNG COMPETITION**  
**Monday, 3/6/2017**

**THREE VERSUS FOUR-FACTOR PROTHROMBIN COMPLEX  
CONCENTRATES FOR "FACTOR-BASED" RESUSCITATION  
IN A PORCINE HEMORRHAGIC SHOCK MODEL**

Donald Moe MD, Michael Lallemand MD, John McClellan MD, Joshua Smith DO, Shannon Marko DVM, Matthew Eckert MD, Matthew Martin MD

**Presenter: Donald M Moe**  
**Senior Sponsor: Matt Martin**

**INTRODUCTION:** Bleeding is a leading cause of preventable death following severe injury. Prothrombin complex concentrates (PCC) treat inborn coagulation disorders and reverse oral anticoagulants, but are also proposed for use in "factor-based" resuscitation strategies for traumatically-injured patients. There is a paucity of studies for this indication, in the setting of acidosis, or that compare 3-factor (3PCC) versus 4-factor (4PCC) products. We aimed to assess and compare their safety and efficacy in a porcine model of severe hemorrhagic shock and coagulopathy.

**METHODS:** 25 adult Yorkshire swine underwent 35% volume hemorrhage, ischemia-reperfusion injury and protocolized crystalloid resuscitation. 17 animals were randomized at 4-hours following model creation to receive a 45 IU/kg dose of either 3PCC or 4PCC. Following interim, an additional 8 animals received a transfusion of two unit-equivalents of autologous plasma prior to 4PCC to better characterize its use. Individual factor levels were drawn at 4 and 6 hours.

**RESULTS:** The model created significant acidosis with mean pH 7.21 and lactate of 9.6 mmol/L. Following PCC, 66.7% of 3PCC animals and 25% of 4PCC animals (regardless of plasma administration) developed consumptive coagulopathy (CC). The animals that developed CC had manifested the "lethal triad" with lower temperatures (36.3 vs 37.8 °C), increased acidosis (pH 7.14 vs 7.27, base excess -12.1 vs -6.5 mEq/L), and worse coagulopathy (prothrombin time 17.1 vs 14.6 seconds, fibrinogen 87.9 vs 124.1 mg/dL) (all  $P < 0.05$ ). Fibrinogen levels at time of PCC administration correlated significantly with development of CC [Figure]. In the absence of a CC, 3PCC and 4PCC improved individual clotting factors with transient improvement of prothrombin time, but there was significant depletion of fibrinogen and platelets with no lasting improvement of coagulopathy.

**CONCLUSIONS:** In a severe hemorrhagic shock model PCC successfully replaced individual clotting factors, but failed to correct coagulopathy and was associated with fibrinogen and platelet depletion. Of greater concern, PCC administration resulted in CC in the more severely ill animals. The incidence of CC was markedly increased with 3PCC versus 4PCC, and these products should be used with caution in this setting.

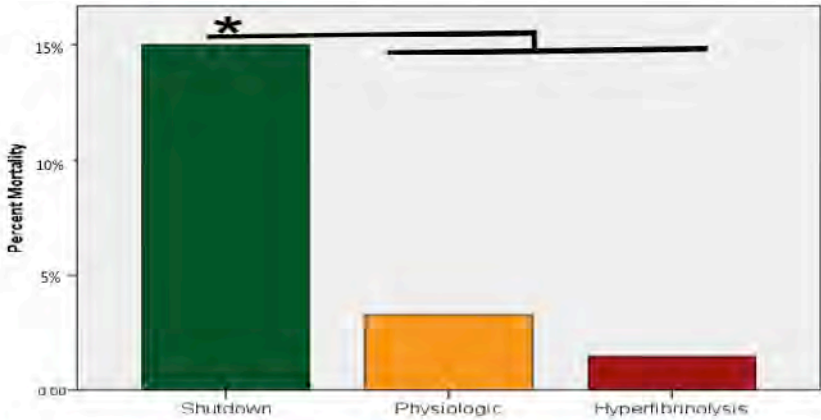

**NOTES**



**Paper# 6 - EARL YOUNG COMPETITION**  
**Monday, 3/6/2017**

**FIBRINOLYSIS SHUTDOWN IS ASSOCIATED WITH A FIVE-FOLD INCREASE IN MORTALITY IN TRAUMA PATIENTS LACKING SENSITIVITY TO TISSUE PLASMINOGEN ACTIVATOR**

HB Moore, EE Moore, BR Huebner, G Stettler, G Nunns, PL Lawson,  
A Ghasabyan, J Chandler, A Banerjee, CC Siliman, A Sawaia  
Denver Health, Denver, CO

**Presenter: Hunter Burroughs Moore**  
**Senior Sponsor: Ernest E. Moore**

**INTRODUCTION:** Fibrinolysis shutdown(SD) is an independent risk factor for increased mortality in trauma. High levels of plasminogen activator inhibitor-1(PAI-1) directly binding tissue plasminogen activator(tPA) is a proposed mechanism for SD, however patients with low PAI-1 levels present to the hospital with a rapid TEG(rTEG) LY30 suggestive SD. We therefore hypothesized that two distinct phenotypes of SD exist, one, which is driven by tPA inhibition, while another is due to an inadequate tPA release in response to injury.

**METHODS:** Trauma activations from our level-1 center between 2014 to 2016 with blood collected within an hour of injury were analyzed with r-TEG and a modified TEG assay to quantify fibrinolysis sensitivity using exogenous tPA(t-TEG). Using the existing rTEG thresholds for SD(2.9%) patients were stratified into phenotypes. A t-TEG LY30 > 95th percentile of healthy volunteers(n=140) was classified as tPA sensitive(tPA-Sen) and used to sub-divide phenotypes. A nested cohort(n=15 per group) had tPA and PAI-1 activity levels measured.

**RESULTS:** This study included 386 trauma activations(median ISS 17), tPA-Sen was present in 27% of patients. Shutdown had the highest mortality rate(20%) followed by hyperfibrinolysis(16%) and physiologic(9% p=0.045). In the non-tPA-Sen cohort, SD had a 5-fold increase in mortality(15%) compared to non-SD patients(3% p=0.003 figure) which remained significant after adjusting for ISS and age (p=0.033). The r-TEG \* t-TEG LY30s strongly correlated to PAI-1(-.505 p<0.001) and tPA activity(.533 p<0.001). PAI-1(p<0.001) and tPA(p=0.002) activity differed overall when comparing fibrinolysis phenotypes subdivided by tPA-Sen. SD with non-tPA-Sen had PAI-1/tPA activity ratio 1,200 times greater than HF with tPA-Sen (9.75 vs 0.008 p=0.002). When evaluating SD patients, PAI-1 activity trended to be higher in non- tPA-Sen vs tPA-Sen group(p=0.080) while tPA activity was similar(p=0.264).

**CONCLUSIONS:** Shutdown is associated with five-fold increased mortality compared to other fibrinolysis phenotypes in the non-tPA-sen cohort and a high ratio of PAI-1/tPA. Fibrinolysis shutdown also exists in patients with tPA-Sen, which is associated with a low endogenous PAI-1 activity, suggestive of a relative inadequate tPA release in response to injury. These two SD phenotypes appear to be driven by different mechanisms and may benefit from different resuscitation strategies.

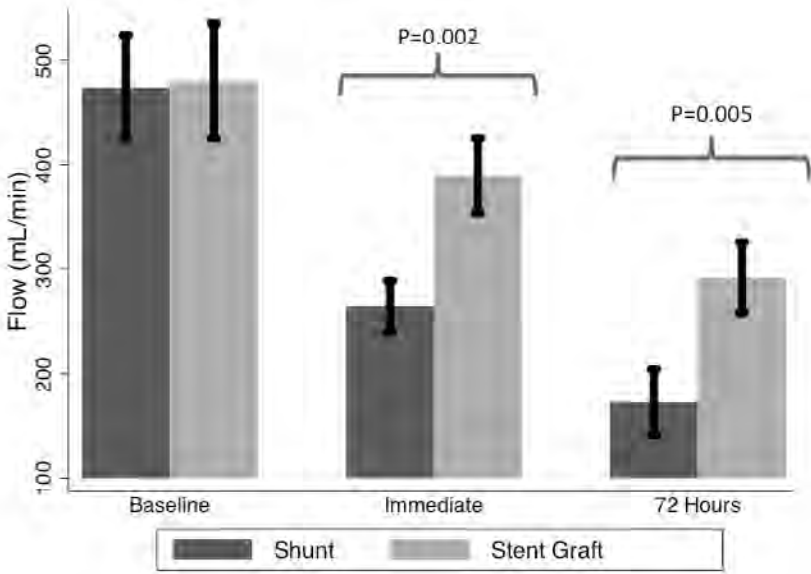

**NOTES**

**COMPARISON OF DIRECT SITE ENDOVASCULAR REPAIR UTILIZING EXPANDABLE PTFE STENT GRAFTS VS. STANDARD VASCULAR SHUNTS IN A PORCINE (SUS SCROFA) MODEL**

AJ Davidson, LP Neff, JK Grayson, ES DeSoucy, MA Simon-Logan, CM Abbot, JB Sampson, TK Williams  
UC Davis/David Grant Medical Center, Sacramento, CA

**Presenter: Anders J Davidson**  
**Senior Sponsor: Matt Martin**

**INTRODUCTION:** The small diameter of temporary vascular shunts for vascular trauma management may restrict flow and result in ischemia or early thrombosis. We have previously reported a clinical experience with direct, open surgical reconstruction using expanded polytetrafluoroethylene (ePTFE) stent grafts to create a “sutureless” anastomosis as an alternative to standard temporary vascular shunts. We sought to characterize patency and flow characteristics of these grafts compared to standard shunts in a survival model of porcine vascular injury.

**METHODS:** 12 Yorkshire-cross swine received a 2cm long near-circumferential defect in the bilateral iliac arteries. A14-French Argyle shunt was inserted into one randomly assigned artery, with a self-expanding ePTFE stent deployed in the other. At 72 hours, conduit patency was evaluated by angiography. Arterial flow measurements were obtained at baseline, immediately after intervention, and after 72 hours via direct measurement with perivascular flow meters. Blood pressure proximal and distal to the conduits and arterial samples for histopathology were obtained during the terminal procedure.

**RESULTS:** Angiography revealed no difference in patency at 72 hours ( $P=1.0$ ). While there was no difference in baseline arterial flow between arteries ( $P=0.63$ ), the stent grafts demonstrated significantly improved blood flow compared to shunts both immediately after intervention ( $390\pm 36\text{mL}/\text{min}$  vs  $265\pm 25\text{mL}/\text{min}$ ,  $p=0.002$ ) and at 72 hours ( $261\pm 29\text{mL}/\text{min}$  vs  $170\pm 36\text{mL}/\text{min}$ ,  $p=0.005$ ). The pressure gradient across the shunts was greater than that of the stent grafts (11.5mmHg IQR[3-19] vs. 3mmHg IQR[3-5],  $p=0.013$ ). The speed of deployment was similar between the two devices.

**CONCLUSIONS:** Open “sutureless” direct site repair using commercially available stent grafts to treat vascular injury is a technically feasible strategy for damage control management of peripheral vascular injury and offers increased blood flow when compared to temporary shunts. Furthermore, stent grafts may offer improved durability to extend the window until definitive vascular repair. The combination of these traits may improve outcomes after vascular injury.

**Table 1.** Overview of Cohort Characteristics and Outcomes.

	Irrigated	Non-Irrigated	OR (p-value)
<b>Cohort Characteristics</b>			
Age (years)	33 (25,51)	47 (27,55)	NA
Male	81.7%	80.5%	NA
Penetrating MOI	51.7%	48.7%	NA
ISS	13 (9,18)	14 (9,22)	NA
AIS-Chest	3 (3,3)	3 (3,3)	NA
<b>Outcomes</b>			
Secondary Intervention	5.5%	21.8%	0.16 (p<.001)
TT Duration	6 (4,7)	6 (4,8)	NS
Length of Stay	7 (5,12)	8 (4,13)	NS
ICU-Length of Stay	1 (0,2)	1 (0,4)	NS

Abbreviations: median (range); ISS: Injury Severity Score; AIS: Abbreviated Injury Scale; TT: Transcatheter Time; MOI: Mechanism of Injury; ISS: Injury Severity Score; AIS: Abbreviated Injury Scale; TT: Transcatheter Time; ICU: Intensive Care Unit.

## NOTES

**Paper# 8 - EARL YOUNG COMPETITION**  
**Monday, 3/6/2017**

**THORACIC IRRIGATION PREVENTS RETAINED HEMOTHORAX:  
A PROSPECTIVE PROPENSITY SCORE MATCHED ANALYSIS**

NW Kugler, TW Carver, DJ Milia, and JS Paul  
Medical College of Wisconsin, Milwaukee, WI

**Presenter: Nathan W Kugler**  
**Senior Sponsor: Jasmeet Paul**

**INTRODUCTION:** Thoracic trauma resulting in hemothorax (HTx) is successfully managed with thoracostomy tube (TT) drainage in the majority of cases. Unfortunately, up to 20% of patients develop retained HTx necessitating secondary interventions, including Video Assisted Thoracoscopic Surgery (VATS) or additional TT placement, for definitive management. We hypothesized thoracic irrigation at the time of TT placement would result in a significant decrease in the secondary intervention rate.

**METHODS:** A prospective, observational trial of all patients with traumatic HTx identified on chest x-ray who underwent lateral TT placement was conducted. The control group consisted of patients within a prospective thoracic trauma database who underwent standard TT placement. The study group underwent both standard TT placement and thoracic irrigation using one liter of warmed sterile saline. A power analysis derived from previously published pilot data was utilized to guide enrollment goals. Patients who underwent immediate thoracotomy, those with TTs removed within 24-hours, or those who died within 30-days of discharge were excluded. A propensity matched analysis was performed with scores estimated using a logistic regression model based on age, sex, mechanism of Injury, abbreviated injury scale (AIS) chest score, and TT size.

**RESULTS:** Over a 30-month period a total of 296 patients underwent TT placement for the management of traumatic HTx. Sixty (20%) patients underwent thoracic irrigation at time of initial TT placement. Cohort characteristics and outcomes are summarized in Table 1. Six patients in the experimental group were excluded: three due to TT removal within 24-hours, two who underwent immediate thoracotomy, and one who died within 30-days. The secondary intervention rate was significantly lower within the study group, 5.6% vs. 21.8% (OR 0.16,  $p < .001$ ).

**CONCLUSIONS:** Thoracic irrigation at the time of initial thoracostomy tube placement for traumatic hemothorax significantly reduced the need for secondary intervention for retained hemothorax. This intervention has the potential to dramatically change chest trauma management. A multi-center randomized clinical trial investigating prophylactic thoracic irrigation for the management of traumatic hemothorax would strengthen the findings of this study.

**NOTES**

**Paper# 9 - EARL YOUNG COMPETITION**  
**Monday, 3/6/2017**

**HUMAN NEUTROPHIL ELASTASE MEDIATES FIBRINOLYSIS SHUTDOWN THROUGH COMPETITIVE DEGRADATION OF PLASMINOGEN AND GENERATION OF ANGIOSTATIN**

CD Barrett, HB Moore, A Banerjee, CC Silliman, EE Moore & MB Yaffe  
Massachusetts Institute of Technology and Beth Israel Deaconess Medical Center, Cambridge, MA

**Presenter: Christopher D. Barrett**  
**Senior Sponsor: Ernest E. Moore**

**INTRODUCTION:** A subset of trauma patients undergo fibrinolysis shutdown rather than pathologic hyperfibrinolysis, contributing to organ failure. The molecular basis for fibrinolysis shutdown in trauma is incompletely understood. Elastase released from primed/activated human neutrophils (HNE) has historically been described as fibrin(ogen)olytic. However, HNE can also degrade plasminogen (PLG) to angiotatin (ANG), retaining the Kringle domains but not the proteolytic function, and could thereby compete for generation of active plasmin by tPA. We hypothesized that HNE can drive fibrinolysis shutdown rather than fibrinolysis.

**METHODS:** Turbidometry was performed using light scatter ( $\lambda=620\text{nm}$ ) in a purified fibrinogen + PLG system and in healthy citrate plasma clotted with  $\text{Ca}^{2+}$ /thrombin -/+tPA, -/+HNE, and -/+ANG to evaluate HNE effects on fibrinolysis, quantified by time to transition midpoint ( $T_m$ ).  $\Delta T_m$  from control is reported as percent of control  $\pm 95\%$ CI. Purified HNE cocubated with PLG or tPA was analysed by western blot to identify cleavage products. Exogenous HNE was mixed ex-vivo with healthy volunteer blood ( $n=7$ ) and used in TEG -/+tPA to evaluate effects on fibrinolysis.

**RESULTS:** HNE did not cause measurable fibrinolysis on fibrin clots, clotted plasma, or whole blood as assessed by turbidometry or TEG in the absence of tPA. Upon tPA treatment, all 3 methods of evaluating fibrinolysis showed delays and decreases in fibrinolysis due to HNE relative to control: fibrin clot turbidometry  $\Delta T_m = 110.7\%$  (CI 105.0%-116.5%), clotted citrate plasma ( $n=6$  healthy volunteers)  $\Delta T_m = 126.1\%$  (CI 110.4%-141.8%), and whole blood native TEG ( $n=7$  healthy volunteers) with  $\Delta \text{LY}30 = 28\%$  ( $p=0.043$ ). Western blot analysis of HNE-PLG co-incubation confirmed that HNE generates angiotatin K1-3, and plasma turbidity assays treated with angiotatin K1-3 delayed fibrinolysis.

**CONCLUSIONS:** HNE degrades PLG and generates angiotatin K1-3, which predominates over HNE cleavage of fibrin(ogen). These findings suggest that neutrophil release of elastase may underlie trauma-induced fibrinolytic shutdown.

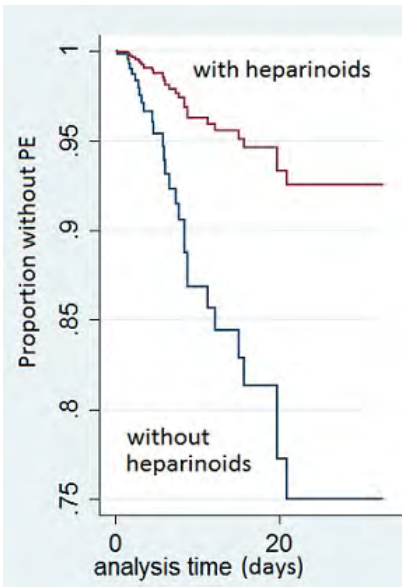

**NOTES**



**EARLY CHEMICAL PROPHYLAXIS IS ASSOCIATED WITH DECREASED PULMONARY EMBOLISM WITHOUT CONCOMITANT INCREASE IN SPINAL CORD HEMATOMA EXPANSION AFTER TRAUMATIC SPINAL CORD INJURY**

R Chang, MH Scerbo, SD Adams, CE Wade, JB Holcomb  
University of Texas Health Science Center at Houston, Houston, TX

**Presenter: Ronald Chang**  
**Senior Sponsor: John B. Holcomb**

**INTRODUCTION:** Chemical prophylaxis with heparinoids and/or aspirin decreases risk of post-traumatic pulmonary embolism (PE), but could also cause expansion of spinal cord hematoma (SCH) and devastating neurologic consequences.

**METHODS:** Single center retrospective study of adult trauma patients from January 2012 to April 2015 with spinal cord injury (SCI). Patients were dichotomized into two groups based on early (≤2 days of arrival) initiation of heparinoid and/or aspirin prophylaxis. SCH expansion was diagnosed intraoperatively or by follow-up radiology. We used multivariable Cox proportional hazards models with heparinoid and aspirin as time-varying covariates to estimate their effect on risk of PE and SCH expansion.

**RESULTS:** There were 17,583 trauma activations, of which 521 (3.0%) had SCI. Of these, 240 (46%) had SCH on admission. Of the 7 (1.3%) patients who had SCH expansion, 4 had worsening motor function including 1 who became quadriplegic. The 263 (50%) patients who received early prophylaxis had decreased blunt mechanism (91% vs 96%,  $p=0.02$ ) and increased ISS (median 24 vs 20,  $p=0.02$ ), but no difference in age (median 43 vs 49) or presence of SCH on admission (47% vs 45%). Median time to initiation of heparinoids and aspirin were 1.12 vs 2.98 days and 1.57 vs 4.27 days respectively. There were no differences in time to initiation of heparin or aspirin in patients with or without SCH on admission.

Patients with early prophylaxis had similar incidence of PE (5% vs 6%), time to PE (7.38 vs 8.46 days), incidence of SCH expansion (1.6% vs 1.1%), and time to expansion (1.97 vs 1.70 days). Using age, ISS, and mechanism as covariates, Cox proportional hazards analysis found that heparinoids (hazard ratio [HR] 0.27, 95% CI 0.09–0.78) (Figure) but not aspirin (HR 1.35, 95% CI 0.58–3.14) was associated with decreased risk of PE. Neither heparinoids (HR 1.89, 95% CI 0.13–11.47) nor aspirin (HR 2.82, 95% CI 0.46–17.44) was associated with risk of SCH expansion. The estimated number needed to treat with heparinoids to prevent one PE at fourteen days after arrival was 9.

**CONCLUSIONS:** Early heparinoid therapy was associated with decreased PE risk in SCI patients without a concomitant increase in SCH expansion.

## Mitochondrial DAMP ND6 Expression Decreases After Washout

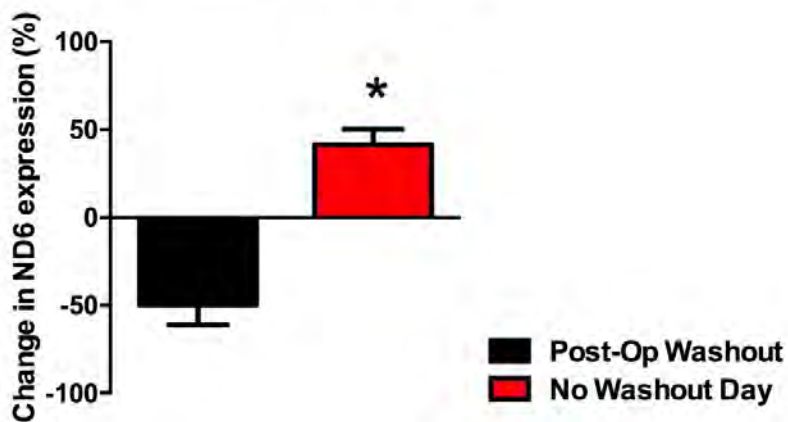

### NOTES

**Paper# 11 - EARL YOUNG COMPETITION**  
**Monday, 3/6/2017**

**PERITONEAL CAVITY LAVAGE REDUCES THE PRESENCE OF  
MITOCHONDRIAL DAMAGE ASSOCIATED MOLECULAR PATTERNS I  
N OPEN ABDOMEN PATIENTS**

PA Martinez Quinones, CG McCarthy, CF Wenceslau, CJ Mentzer, SB Holsten,  
RC Webb, KF O'Malley  
Medical College of Georgia at Augusta University, Augusta, GA

**Presenter: Patricia Martinez Quinones**  
**Senior Sponsor: Keith O'Malley**

**INTRODUCTION:** Mitochondrial damage-associated molecular patterns (DAMPs), such as mitochondrial DNA and N-formyl peptides, are potent activators of the innate immune system. This is thought to occur because their similarities with bacteria, which allows mtDAMPs to interact with the same pattern recognition receptors. Traumatic tissue injury causes the release of these endogenous molecules, known as DAMPs that may mediate the development of Systemic Inflammatory Response Syndrome (SIRS). Current recommendations for management of an open abdomen include returning to the operating room every 48 hours for peritoneal cavity lavage until definitive procedure. These patients are often critically ill and develop SIRS. We hypothesized that mitochondrial DAMPs are present in the peritoneal cavity fluid in this setting, and that they accumulate in the interval between washouts.

**METHODS:** We conducted a prospective pilot study of critically ill adult patients undergoing open abdomen management in the Surgical and Trauma ICUs. Peritoneal fluid was collected daily from 9 open abdomen patients. Specimens were analyzed via qPCR for mitochondrial DNA (mtDNA), via enzyme immunoassay for DNase activity and via Western blot analysis for the ND6 subunit of the NADH: ubiquinone oxidoreductase (an N-formylated peptide which is complex I of the mitochondrial respiratory chain).

**RESULTS:** We observed a reduction in the expression of ND6 the day following lavage of the peritoneal cavity, that was statistically different from the days with no lavage (% change in ND6 expression, Post-Op from washout:  $-50\pm 11$  vs. No Washout day:  $42\pm 9$ ,  $p < 0.05$ ). Contrary to expectation, the mtDNA levels remained relatively constant from sample to sample. We then hypothesized that DNase present in the effluent may be degrading mtDNA. However, attempts to measure DNase activity were unsuccessful, presumably because the samples were too dilute for measurement.

**CONCLUSIONS:** These results indicate the peritoneal cavity washout reduces the presence of mitochondrial DAMPs in the open abdomen. Therefore, increased frequency of peritoneal cavity lavage may lead to decreased systemic absorption of deleterious DAMPs, and ultimately a reduced risk of SIRS. The precise relationship between clinical outcomes (such as SIRS) with mtDAMPs in peritoneal fluid and systemic circulation of critically ill patients is the focus of our ongoing study.

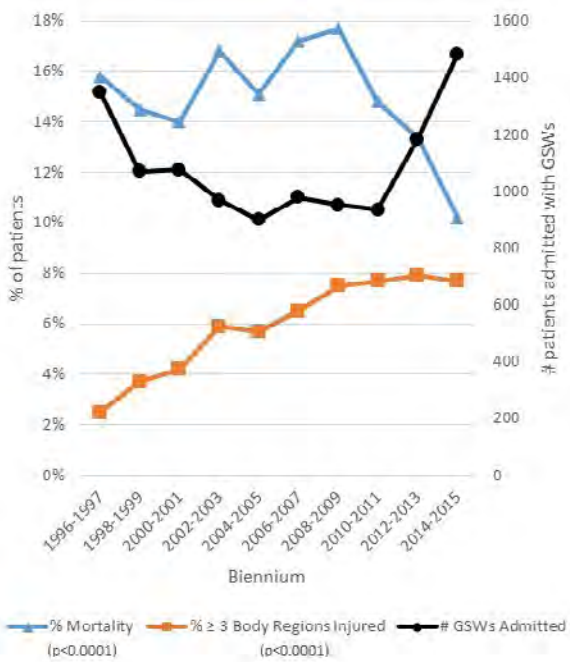

**NOTES**

**Paper# 12 – EARL YOUNG COMPETITION**  
**Monday, 3/6/2017**

**GOOD NEWS, BAD NEWS: AN ANALYSIS OF 11,294 GUNSHOT WOUNDS  
OVER TWO DECADES IN A SINGLE CENTER**

NR Manley, TC Fabian, JP Sharpe, LJ Magnotti, MA Croce  
University of Tennessee Health Science Center, Memphis, TN

**Presenter: Nathan R Manley**  
**Senior Sponsor: Martin Croce**

**INTRODUCTION:** Gun violence is a substantial public health problem accounting for significant physical, psychological and financial costs. While aggregate data sources demonstrate decreasing rates of firearm violence, analyses from individual trauma centers have shown that mortality and injury severity from GSWs are increasing. To evaluate the evolving characteristics of gun violence in our region, we studied all GSWs admitted to our trauma center over a twenty-year period.

**METHODS:** A retrospective analysis of all newly admitted patients with GSWs was performed from 1996 to 2016. Patients who presented with GSWs who were treated and discharged from the trauma center were excluded. Our trauma registry was used to collect data on demographics, mortality, injury severity, body regions injured and geographic location of injury. Homicide data was obtained from local law enforcement to serve as a point of comparison to registry data.

**RESULTS:** 11,294 patients with GSWs were reviewed. The number of GSWs treated per biennium increased from 1,349 in 1996-1997 to 1,484 in 2014-2015, with a 59% percent increase occurring from 2010-2011 to 2014-2015. Overall mortality was 14.6% and decreased from 15.8% in 1996-1997 to 10.2% in 2014-2015 ( $p < 0.0001$ ). Mean injury severity score (ISS) was 12.6 and the percent of patients who suffered GSWs to  $\geq 3$  AIS body regions increased from 2.5% in 1996-1997 to 7.7% in 2014-2015 ( $p < 0.0001$ ). Local homicide data shows a 103% increase from 2010 to 2016.

**CONCLUSIONS:** In contrast to other recent studies, we found that mortality decreased while the number of patients treated for GSWs and those with multi-compartmental injuries increased. The decrease in mortality suggests improved trauma systems, as well as an increase in non-fatal GSWs that dilutes overall mortality. Wounding in multiple body regions suggests the increased use of semi-automatic weapons and/or higher capacity magazines. The recent increase in local homicides parallels trends in registry data and illustrates worsening gun violence in our region. Further research is needed to understand local and regional determinants of increased gun violence to better guide prevention strategies.

**A**

SSRF Frequency and Mortality by Region

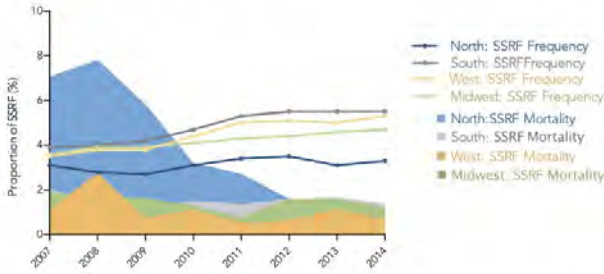

	2007	2008	2009	2010	2011	2012	2013	2014
North	3.1%	2.8%	2.7%	3.1%	3.4%	3.5%	3.1%	3.3%
South	3.9%	4.0%	4.2%	4.7%	5.3%	5.5%	5.5%	5.5%
West	3.5%	3.8%	3.8%	4.4%	5.0%	5.1%	5.0%	5.3%
MidWest	3.6%	3.9%	3.9%	4.1%	4.3%	4.4%	4.6%	4.7%

**B**

SSRF Frequency and Mortality by ACS Level

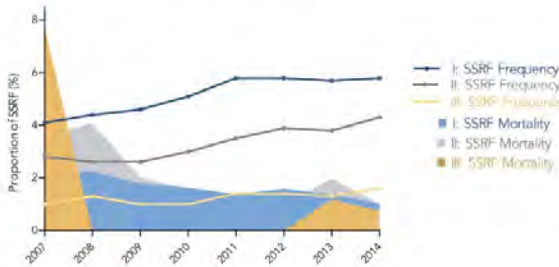

	2007	2008	2009	2010	2011	2012	2013	2014
I	4.1%	4.4%	4.6%	5.1%	5.8%	5.8%	5.7%	5.8%
II	2.8%	2.6%	2.6%	3.0%	3.5%	3.9%	3.8%	4.3%
III	1.0%	1.3%	1.0%	1.0%	1.4%	1.4%	1.3%	1.6%

**NOTES**

**SURGICAL STABILIZATION OF RIB FRACTURES: INCREASING AT AN ALARMING RATE?**

ED Kane, E Jeremitsky, FM Pieracci, S Majercik, SR Smith, AR Doben  
Baystate Medical Center, Springfield, MA

**Presenter: Erica D Kane**  
**Senior Sponsor: Stephen R. Smith**

**INTRODUCTION:** Surgical Stabilization of Rib Fractures (SSRF) has become pivotal and increasingly popular in the management of severe chest injuries. Recent literature supports improved outcomes and mortality in severe fracture and flail chest patients who undergo SSRF compared to non-operative management. A 2014 National Trauma Data Bank (NTDB) review provided a point prevalence of 0.8% SSRF in flail patients. We hypothesize that this prevalence is increasing and that temporal, regional, and American College of Surgeons (ACS) trauma designation vary in SSRF utilization.

**METHODS:** Retrospective NTDB data was extracted for years 2007-2014 for patients with rib fractures (dcodes 807-807.4). Cases were divided into SSRF (pcode 79.39) versus Non-operative management (NOM). SSRF frequencies and outcomes were analyzed across year, region, facility ACS level, and case volume. Patient demographics, injury severity score, number of fractured ribs, and hospital characteristics were identified for multivariable analysis.

**RESULTS:** Between 2007-2014, 687,137 rib fracture patients were identified; 29,981 (4.36%) underwent SSRF. SSRF increased by 76% nationally over the 8-year review period (OR 1.59, 95% CI 1.50-1.67;  $P < 0.001$ ). Compared to the North, SSRF was utilized more in the West (OR 1.6, 95% CI 1.57-1.71), South (OR 1.48, 95% CI 1.43-1.54), then Midwest (OR 1.4, 95% CI 1.34-1.46,  $p < 0.001$ , Figure A). While likelihood of SSRF is higher at ACS Level 1 Centers (LI) compared to Level 2 Centers (LII) (OR 0.67, 95% CI 0.65-0.69) or Level 3 (LIII) (OR 0.24, 95% CI 0.22-0.26);  $p < 0.001$ , frequency of SSRF increased precipitously at lower level centers from 2007-2014 (LI 41.4%, LII 53.6%, LIII 60.0%; Figure B). Patients were more likely to undergo SSRF at community hospitals (OR 1.09, 95% CI 1.06-1.13;  $p < 0.001$ ) compared to university hospitals.

Overall SSRF mortality was 1.58% (NOM 5.3%;  $p < 0.001$ ), decreasing significantly between 2007-2014 ( $p < 0.0001$ ). ACS LII had higher mortality than LI (OR 1.82, 95% CI 1.39-2.39;  $p < 0.0001$ ), controlled by ISS.

**CONCLUSIONS:** Utilization of SSRF has exploded nationally. Prevalence varies by region and ACS level. While greatest growth is occurring at LII hospitals, mortality is also the highest at these centers. Further research is needed to determine need for regionalization of care and center of excellence designation.

**NOTES**



**Pro/Con Debate**  
**Tuesday, 3/7/2017**

**PRO-CON: RIB FRACTURES: TO PLATE OR NOT- WHERE IS THE DATA?**

**Pro: Marc DeMoya**

**Con: Oscar Guillamondegui**

**NOTES**

**Paper# 14**  
**Tuesday, 3/7/2017**

## **THYROID STORM INDUCED BY TRAUMA: A CHALLENGING COMBINATION**

SN Davis, R McIntyre, C Cribari, JA Dunn  
University of Colorado Denver, Aurora, CO

**Presenter: Stephanie N. Davis**  
**Senior Sponsor: Robert McIntyre**

**INTRODUCTION:** Thyroid storm is rare and potentially lethal. There are no universally accepted criteria for diagnosis and signs and symptoms of tachycardia, hypotension, agitation and delirium mimic those seen in trauma patients. Early recognition and treatment is essential to prevent death.

**METHODS:** **Patient # 1** was a 54 year old male involved in a motorcycle crash. Upon arrival he was awake, perseverating, and intermittently combative. His workup revealed a right humerus and left femur fractures. His wife reported no significant medical illnesses. A goiter was present on exam. **Patient #2** was a 57 year old female involved in a motor vehicle accident, sustaining radius and tibial plateau fractures and pulmonary contusions. She was in atrial fibrillation upon arrival which responded to beta-blockade. She reported a history of hyperthyroidism but was non-compliant with medication.

**RESULTS:** **Patient #1** was taken to the operating room for orthopedic repair. After surgery he became tachycardic and hypertensive, followed by fever and hypotension requiring vasopressors. Free T4 was greater than 6 ng/dl and TSH 0.07 UIU/ml. Hydrocortisone and methimazole were started, followed by iodine. Repeat abdominal CT showed intra-abdominal fluid without solid organ injury and the lactate was 4.3 mmol/L. He underwent exploratory laparotomy which was negative. Plasmapheresis was started. He deteriorated, became unresponsive to pressors, developed DIC and multiple organ failure, and died on hospital day #4. **Patient #2** was found to have a TSH < .008 and free T3 > 20 pg/ml. She was treated with beta-blockade, methimazole, and steroids. On day #4 she developed confusion, hypotension, and acidosis. Thyroid hormone levels remained elevated and she developed acute fulminant hepatotoxicity. Thionamides were discontinued and she underwent plasmapheresis prior to urgent thyroidectomy. Following surgery she developed Takotsubo cardiomyopathy, but eventually recovered.

**CONCLUSIONS:** Thyroid storm in trauma patients is a rare event with a high mortality rate. Prompt recognition may be difficult in the trauma patient. Initiation of early and aggressive treatment is critical. Management includes supportive care, antithyroid medication, steroids, iodine, beta-blockade, and plasmapheresis. Thyroidectomy may be considered in patients who do not respond to medical therapy and can be successful.

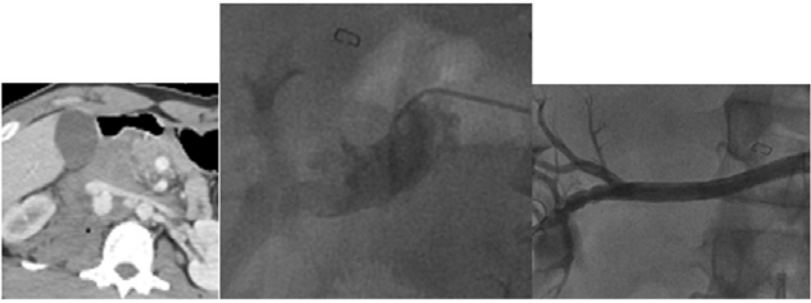

**NOTES**

**Paper# 15**  
**Tuesday, 3/7/2017**

## **HEMATOMAS IN TIGER TERRITORY: AN ENDOVASCULAR ALTERNATIVE TO WADING IN**

D Teso, Y Vea, B Rogoway, J Threlkeld, G Dulabon  
Peacehealth Southwest Medical Center, vancouver, WA

**Presenter: Desarom Teso**  
**Senior Sponsor: Riyad Karmy-Jones**

**INTRODUCTION:** We have all been educated about the importance of exploring retroperitoneal hematomas after penetrating trauma. Over the past years, endovascular approaches have been advocated in stable patients as an alternative approach which offers less blood loss and more control, albeit in select patients

**METHODS:** A 25 year old males presented with a 9 mm gunshot wound that entered just to the left of the xiphoid and exited his right posterior flank at L2 level. He was hemodynamically stable, E-fast identified a small amount of peritoneal fluid only, and CXR was normal. CT scan was performed which identified: free peritoneal fluid; right hepatic artery and portal vein transection; through and through left liver injury; left renal vein transection; right renal artery laceration and pseudoaneurysm behind the IVC; contusion to head of pancreas. At laparotomy the liver was packed. There were tense contained but not expanding hematomas, one in the portal triad the other over and between Gerota™ fascia, the third portion of the duodenum and the IVC. These were not opened. The patient was packed and taken to the Cath lab.

**RESULTS:** At angiography the right hepatic artery was found to be patent but have a dissection. However flow was maintained. The right renal artery had a pseudoaneurysm with fistula to the IVC. This was repaired with two Viabahn stents. The trauma team at follow up surgery were able to perform retrograde cystourethrogram and close the abdomen. The patient made a complete recovery and was discharged on POD 10. At follow up based on duplex the renal artery stent is patent, the left renal vein, portal vein and hepatic artery have normal contour and flow.

**CONCLUSIONS:** Endovascular approaches have created an alternate path to managing potential vascular injuries. The advantages include not unroofing a contained injury with blood loss and difficult reconstruction. In this case the key deterrent was the surgical observation that the patient was stable, did not have ongoing blood loss and the hematomas were, although firm, not expanding. In select cases this may offer an alternate route to wide open exploration.

**NOTES**

**Paper# 16**  
**Tuesday, 3/7/2017**

**REBOA FOR THE IVC? RESUSCITATIVE BALLOON OCCLUSION OF THE INFERIOR VENA CAVA (REBOVC) TO ABATE MASSIVE HEMORRHAGE IN RETRO-HEPATIC VENA CAVA INJURIES**

CL Reynolds, AC Celio, LC Bridges, C Mosquera, B O'Connell, CM Dela'o, MR Bard, EA Toschlog  
East Carolina University, Greenville, NC

**Presenter: Cassandra Lane Reynolds**  
**Senior Sponsor: Eric Toschlog**

**INTRODUCTION:** The use of resuscitative endovascular balloon occlusion as a lifesaving maneuver for occlusion of the aorta and prevention of massive hemorrhage is well described. This technique has life-saving potential in other cases of traumatic hemorrhage. Retro-hepatic inferior vena cava (IVC) injuries have a high rate of mortality due at least in part to the difficulty in achieving total vascular isolation, particularly the supra-hepatic IVC. The purpose of our study was to investigate the ability of resuscitative balloon occlusion of the IVC (REBOVC) to control supra-hepatic IVC hemorrhage in a swine model of liver trauma.

**METHODS:** Thirteen swine were randomly assigned to two groups; 7 to the control group and 6 to the intervention group. In both groups, an injury was created to the peri-hepatic IVC approximately 25% of the diameter. Hepatic inflow control was obtained via clamping of the hepatoduodenal ligament and infra-hepatic IVC. In the intervention group, supra-hepatic IVC control was obtained via an endovascular occlusion balloon placed through the femoral vein. In the control group, no supra-hepatic IVC control was established. Vital signs, arterial blood gases and lactate were monitored until death or up to one hour. Blood loss and time to death were the primary endpoints. Lactate, pH, and vital signs were secondary endpoints. Groups were compared using chi square and Student's t test with significance at  $p < 0.05$ .

**RESULTS:** Time to death was significantly prolonged in the intervention group; 59.3 ( $\pm 1.6$ ) vs 33.4 ( $\pm 12.0$ ) minutes ( $p = 0.001$ ). Total blood loss was significantly reduced in the intervention group; 333.3 ( $\pm 122.6$ ) vs 1701.6 ( $\pm 358.5$ ) mL ( $p = 0.001$ ). In the intervention group, 5 of the 6 swine were alive at 1 hour (83.3%) compared to 0 of 7 (0%) in the control group ( $p = 0.002$ ). There was a trend toward worsening acidosis, hypothermia, elevated lactate and hemodynamic instability in the control group.

**CONCLUSIONS:** Resuscitative endovascular balloon occlusion of the supra-hepatic IVC (REBOVC) demonstrates superior hemorrhage control and prolonged time to death in a swine model of liver hemorrhage. This technique may be considered as an adjunct to total hepatic vascular isolation in severe liver hemorrhage and could provide additional time needed for definitive repair.

Table. Patient characteristics and outcomes	Overall (n=223)	Open (n=135)	Endovascular (n=38)	Hybrid (n=14)	Non-operative (n=36)
Median ISS (IQR)	17 (10 – 26)	17 (10 – 25)	20 (16 – 34)	14 (9 – 16)	18 (10 – 29)
Artery type*					
Axillary	103 (46)	74 (72)	12 (12)	7 (7)	10 (10)
Subclavian	104 (47)	51 (49)	23 (22)	6 (6)	24 (23)
Both	16 (7)	10 (63)	3 (19)	1 (6)	2 (13)
Mechanism of injury, n (%)					
Blunt	95 (43)	48 (51)	22 (23)	1 (1)	20 (21)
Gunshot wound	97 (43)	62 (64)	13 (13)	8 (4)	14 (14)
Shotgun	3 (1)	2 (67)	1 (33)	0	0
Stab wound	24 (11)	15 (63)	2 (8)	5 (21)	2 (8)
Other	4 (2)	4 (100)	0	0	0
Diagnostic modality, n (%)**					
Conventional angiography	42 (19)	26 (62)	7 (17)	4 (10)	5 (12)
CT angiography	112 (50)	53 (47)	26 (23)	6 (5)	27 (24)
Intraoperative	54 (24)	51 (94)	1 (2)	1 (2)	1 (2)
Not reported	3 (1)	0	1 (33)	1 (33)	1 (33)
Other	12 (5)	5 (42)	3 (25)	2 (17)	2 (17)
Injury Grade**	n= 203	n= 122	n= 34	n= 14	n= 33
A: Minimal injury (intima only)	22 (11)	1 (5)	5 (23)	2 (9)	14 (64)
B: <25% circumference laceration	9 (4)	6 (67)	2 (22)	1 (11)	0
C: 25-50% circumference laceration	6 (3)	5 (83)	1 (17)	0	0
D: 50% circumference laceration	14 (7)	13 (93)	0	1 (7)	0
E: Pseudoaneurysm	36 (18)	8 (22)	15 (43)	1 (3)	12 (33)
F: Vessel transection	72 (35)	60 (83)	5 (7)	7 (10)	0
G: Occlusion	44 (22)	29 (66)	6 (14)	2 (5)	7 (16)
Subclavian vein injury	28 (13)	23 (17)	2 (5)	1 (7)	2 (6)
Brachial plexus injury*	59 (26)	47 (80)	4 (7)	1 (2)	7 (12)
Hemorrhage requiring re-exploration	7 (3)	5 (4)	1 (3)	1 (7)	0
Graft thrombosis	7 (8)	5 (5)	0	2 (2)	--
Stent thrombosis	3 (6)	0	3 (6)	0	--
Graft infection	3 (3)	3 (3)	0	0	--
Stent infection	1 (2)	0	1 (2)	0	--
Brachial plexopathy**	14 (6)	9 (60)	3 (8)	1 (7)	1 (3)
Re-intervention	17 (8)	11 (8)	3 (8)	3 (21)	--
Amputation	7 (3)	5 (4)	2 (5)	0	0
In-hospital death	23 (10)	16 (12)	3 (8)	2 (14)	2 (6)

\*P<0.05 and \*\*P<0.001 for comparison between management techniques.



**CONTEMPORARY MANAGEMENT OF SUBCLAVIAN AND AXILLARY ARTERY INJURIES - A WESTERN TRAUMA ASSOCIATION MULTICENTER REVIEW**

CJ Waller, TH Cogbill, KJ Kallies, LD Ramirez, JM Cardenas, SR Todd, KJ Chapman, M Beckman, JL Sperry, VP Anto, EA Eriksson, SM Leon, RJ Anand, M Pearlstein, L Capano-Wehrle, C Cothren Burlew, CJ Fox, DC Cullinane, JC Roberts, PB Harrison, GM Berg, JM Haan  
Gundersen Medical Foundation, La Crosse, WI

**Presenter: Christine J. Waller**  
**Senior Sponsor: Thomas Cogbill**

**INTRODUCTION:** Subclavian and axillary artery injuries are uncommon. In addition to many open vascular repairs, endovascular techniques are used for definitive repair or vascular control of these anatomically challenging injuries. The aim of this study was to determine the relative roles of endovascular and open techniques in the management of subclavian and axillary artery injuries comparing hospital outcomes, and long-term limb viability.

**METHODS:** A multicenter, retrospective review of patients with subclavian or axillary artery injuries from 1/1/2004-12/31/2014 was completed at 11 participating Western Trauma Association institutions. Statistical analysis included  $\chi^2$ , t-tests, and Cochran-Armitage trend tests. *P*-value <0.05 was significant.

**RESULTS:** 223 patients were included; mean age was 36 years, 84% were male (Table). An increase in CT angiography and decrease in conventional angiography was observed over time (*P*=0.018). There were 120 subclavian and 119 axillary artery injuries. Procedure type was associated with injury grade (*P*<0.001). Open operations were performed in 135 (61%) patients, including 93% of >50% circumference lacerations and 83% of vessel transections. Endovascular repairs were performed in 38 (17%) patients; most frequently for pseudoaneurysms. Fourteen (6%) patients underwent a hybrid procedure. Use of endovascular versus open procedures did not increase over the duration of the study (*P*=0.248). In-hospital mortality rate was 10%. Graft or stent thrombosis occurred in 7% and graft or stent infection occurred in 3% of patients. Mean follow-up was 1.6±2.4 years (n=150). Limb salvage was achieved in 216 (97%) patients.

**CONCLUSIONS:** The management of subclavian and axillary artery injuries still requires a wide variety of open exposures and procedures, especially for the control of active hemorrhage from >50% vessel lacerations and transections. Endovascular repairs were used most often for pseudoaneurysms. Low early complication rates and limb salvage rates of 97% were observed after open and endovascular repairs.

	PCW + drain (N=5)	Sternotomy (N=7)	p
Age, years	29 (25-51)	35 (17-52)	0.63
Male (%)	4 (80%)	7 (100%)	0.42
KSW (%)	5 (100%)	6 (86%)	1.0
Ex Lap (%)	2 (40%)	3 (43%)	1.0
Hospital LOS, d	5 (3-15)	7 (3-28)	0.63
ICU LOS, d	4 (2-10)	2 (1-28)	0.18
Vent Days, d	1 (0-4)	0 (0-27)	0.36
Hospital Mortality	0 (0%)	0 (0%)	-

All variables display median (range) or quantity (percent)

**NOTES**

**Paper# 18**  
**Tuesday, 3/7/2017**

**SELECTIVE USE OF PERICARDIAL WINDOW AND DRAINAGE AS SOLE TREATMENT FOR HEMOPERICARDIUM FROM PENETRATING CHEST TRAUMA**

PJ Chestovich, CF McNicoll, PP Patel, E Clark, DR Fraser, DA Kuhls, JJ Fildes  
University of Nevada School of Medicine, Las Vegas, NV

**Presenter: Paul J. Chestovich**  
**Senior Sponsor: John Fildes**

**INTRODUCTION:** Sternotomy is considered mandatory for penetrating chest trauma with hemopericardium. Recent international literature suggests this may be unnecessary in stable patients with superficial cardiac injuries. This study analyzes treatment of hemopericardium following penetrating chest trauma with pericardial window (PCW), drainage, and close monitoring for cessation of bleeding.

**METHODS:** All penetrating chest trauma patients from 2000-2016 requiring PCW or sternotomy at an urban ACS-verified Level 1 trauma center were retrospectively reviewed. Data was collected for patients who had PCW for hemopericardium managed with only pericardial drain, or underwent sternotomy for cardiac injuries grade 1-3 according to the AAST cardiac Organ Injury Scale (OIS). Grade 1-3 injuries were included because they are partial thickness and often stop bleeding without suture repair. The PCW + drainage group was compared to the sternotomy group using Fisher's exact and Wilcoxon Rank-sum test with  $p < 0.05$  considered significant.

**RESULTS:** Sternotomy was performed in 57 patients for suspected penetrating cardiac injury. Of these, 7 patients had AAST OIS grade 1-3 injuries (Sternotomy group). PCW was performed in 37 patients, and 21 had hemopericardium; 16 patients proceeded to sternotomy and 5 were treated with pericardial drainage and close monitoring (PCW + drain group). All PCW + drainage patients had suction evacuation of hemopericardium, pericardial lavage, and cessation of intra-operative bleeding, followed by pericardial drain placement and admission to ICU. Average volume of blood drained was 240 ml (40 - 600). Drains were removed on average POD 3.6 (2-5). Comparisons between the PCW + drain and Sternotomy groups are shown in the table. There was no significant difference in demographics, injury mechanism, exploratory laparotomies, hospital or ICU length of stay (LOS), ventilator days, or hospital mortality.

**CONCLUSIONS:** Patients with penetrating chest trauma and hemopericardium who are hemodynamically stable may be safely managed with pericardial window, lavage and drainage with documented cessation of intra-pericardial bleeding, and post-operative ICU monitoring. There is no difference in outcomes with sternotomy for similar injuries. Further work through a multi-center study can evaluate potential changes to established management guidelines of hemopericardium caused by penetrating chest trauma.

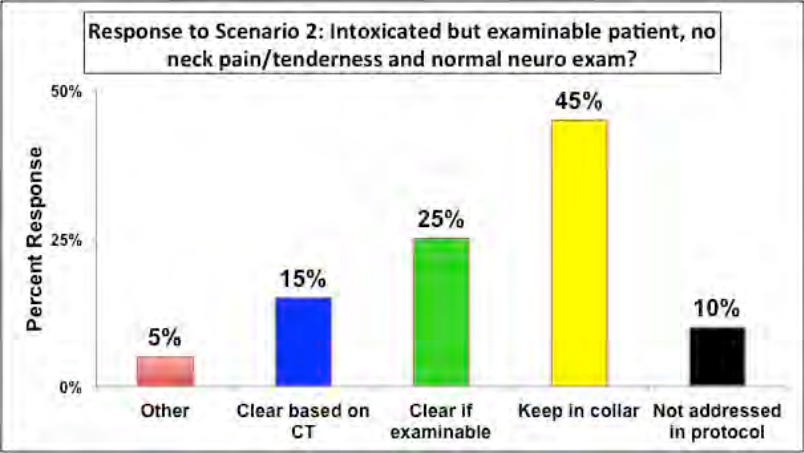

**NOTES**

**Paper# 19**

**Tuesday, 3/7/2017**

**CERVICAL SPINE EVALUATION AND CLEARANCE IN THE INTOXICATED PATIENT: A PROSPECTIVE WTA MULTI-INSTITUTIONAL TRIAL AND SURVEY**

MJ Martin, LD Bush, K Inaba, S Byerly, M Schreiber, KA Peck, G Barmparas, J Menaker, JP Hazelton, R Coimbra, MD Zielinski, CVR Brown, CG Ball, JR Cherry-Bukowiec, CC Burlaw, J Dunn, T Minshall, MM Carrick, GM Berg, D Demetriades, W Long, and the WTA C-Spine Study Group  
Legacy Emanuel Medical Center, Portland, OR

**Presenter: Matthew Martin**

**Senior Sponsor: Matthew Martin**

**INTRODUCTION:** Intoxication often prevents clinical clearance of the cervical spine (Csp) after trauma leading to prolonged immobilization even with a normal CT scan. We evaluated the accuracy of CT at detecting clinically significant Csp injury, and surveyed participants on related opinions and practice.

**METHODS:** A prospective multicenter study (2013-2015) at 17 centers. All adult blunt trauma patients underwent structured clinical examination and imaging including a Csp CT, with follow-up thru discharge. EtOH and drug intoxicated patients (TOX+) were identified by serum and/or urine testing. Primary outcomes included the incidence and type of Csp injuries, the accuracy of CT scan, and the impact of TOX+ on the time to Csp clearance. A 36-item survey querying local protocols, practices, and opinions in the TOX+ population was administered.

**RESULTS:** 10,191 patients were prospectively enrolled and underwent CT Csp during the initial trauma evaluation. The majority were male (67%), vehicular trauma or falls (83%), with mean age=48, and mean ISS=11. The overall incidence of Csp injury was 10.6%. TOX+ comprised 30% of the cohort (19% EtOH only, 6% drug only, and 5% both). TOX+ were significantly younger (41 vs 51,  $p<0.01$ ) but with similar mean ISS (11) and GCS (13). The TOX+ cohort had a lower incidence of Csp injury vs non-intoxicated (8.4 vs 11.5%,  $p<0.01$ ). In the TOX+ group, CT had a sens=94%, spec=99.5%, and NPV=99.5% for all Csp injuries. For clinically significant injuries, the NPV was 99.9%, and there were no unstable Csp injuries missed by CT (NPV=100%). When CT Csp was negative, TOX+ led to longer immobilization vs sober patients (mean 8 hrs vs 2 hrs,  $p<0.01$ ), and prolonged immobilization (>12hrs) in 25%. The survey showed marked variations in protocols, definitions, and Csp clearance practices among participating centers (Figure), although 100% indicated willingness to change practice based on this data.

**CONCLUSIONS:** For intoxicated patients undergoing Csp imaging, CT scan was highly accurate and reliable for identifying clinically significant spine injuries, and had a 100% NPV for identifying unstable injuries. CT-based clearance in TOX+ patients appears safe and may avoid unnecessary prolonged immobilization. There was wide disparity in practices, definitions, and opinions among the participating centers.

**NOTES**

**Paper# 20**

**Tuesday, 3/7/2017**

**DON'T CALL ME CRAZY! DELIRIUM OCCURS OUTSIDE OF THE ICU**

CP Percy, A Cahill, K Almahmoud, PL Sladek, V Agrawal, MS Truitt  
Methodist Dallas Medical Center, Dallas, TX

**Presenter: Michael Truitt**

**Senior Sponsor: Michael Truitt**

**INTRODUCTION:** Delirium has been well studied among critically ill populations in the ICU; however, data available for delirium beyond the ICU is limited. The purpose of this study is to evaluate the incidence and associated risk factors for delirium in the ward.

**METHODS:** After IRB approval, a prospective cohort study was conducted at our urban Level 1 Trauma Center. All patients admitted to the ward by a trauma surgeon were included. The Confusion Assessment Method (CAM) was administered every 12 hours until discharge. Those who screened positive for delirium (CAM+) were administered the CAM-S to quantify the severity of delirium. Demographics, laboratory data, and inpatient medication lists were collected. Fisher exact test was employed to determine statistical significance between groups.

**RESULTS:** Of the 148 participants, 12 (8%) were CAM+ and 136 (92%) were non-delirious (CAM-). Average severity score of CAM+ patients was  $14 \pm 2$ , on a scale from 0 to 19. Average age of all patients was  $52 \pm 20$  years old and 45% were male. Of patients  $\geq 65$  years old, 9 (20%) were CAM+. Our analysis of 120,049 data points revealed that CAM+ patients were statistically more likely to be on the following medications: Albuterol (0.01), Atorvastatin (0.01), Duloxetine (0.04), Sertraline (0.04), Folic Acid (0.01), Thiamine (0.01), Vitamin D ( $<0.001$ ), Haloperidol (0.04), Metoprolol (0.02), and Vancomycin (0.02). Abnormal lab values associated with delirium included: Albumin (0.03, OR 7.9, CI 0.996-63.203), Calcium (0.011, OR 5.0, CI 1.465-16.707), Sodium (0.04, OR 3.9, CI 1.134-13.494), and Hematocrit (0.04, OR N/A).

**CONCLUSIONS:** To our knowledge, this is the first study to evaluate the incidence of delirium on the ward. Our study found an overall 8% incidence of delirium. This increased to 20% in patients  $\geq 65$  years old. Many of the risk factors identified in our study of ward patients are consistent with those reported in the ICU. In contrast to the ICU, our CAM+ patients had lower albumin, lower hematocrit, and were more likely to be on vancomycin, vitamin D and folate. Given the results of our study, screening of ward patients with these risk factors should be considered.

**NOTES**



**Paper# 21**  
**Tuesday, 3/7/2017**

**IN AN INSTANT: HOW AN ACT OF GUN VIOLENCE NEARLY TORE OUR FAMILIES APART**

AL Eastman, CT Minshall and JP Minei  
The Rees-Jones Trauma Center at Parkland and The Dallas Police Department,  
Dallas, TX

**Presenter: Alexander L Eastman**  
**Senior Sponsor: Alexander L Eastman**

**INTRODUCTION:** Trauma Centers and trauma teams often function like a family. However, in an instant, a gunman shattered a peaceful protest and nearly decimated our families. The five police officers killed and nine others wounded challenged our trauma system to respond. Yet, that response only represented the beginning for our trauma family and our community. Once the paperwork is done, rooms are cleaned and blood replenished, the true challenge was in healing our trauma family across all disciplines.

**METHODS:** Violence in urban America seems to be on the rise. Trauma centers, often the final common place where multiple families come together are ill prepared for the aftermath of these events. Going far beyond traditional crisis response, we examined how issues of violence, healing, race, policing and each of our roles in this crisis drove us to the brink as a family.

**RESULTS:** Despite close interpersonal relationships and an interwoven group practice, a crisis like this can drive deep wedges between even the closest of friends and colleagues. Each of our unconscious biases not only colors how we respond to this crisis but when magnified by the microscope of media attention, these biases can become obstacles.

**CONCLUSIONS:** To heal, to emerge stronger and to move forward, our trauma family, our institutions and our communities had to come together and have tough conversations, deep discussion and even tears between us all. While much has previously been written on the topic of resilience and recovery, much more work is needed to ensure our trauma teams are at best insulated or at basic, prepared not just to respond to these crises, but to recover from them as well.

**NOTES**

**Paper# 22 - FAMILY ABSTRACT**  
**Tuesday, 3/7/2017**

**SEVEN DECADES OF SKIING-A TALE OF TWO BROTHERS**

CC Baker  
Caswell Beach, NC

**Presenter: Christopher C. Baker**  
**Senior Sponsor: Christopher Baker**

Growing up in New Hampshire, these two brothers first learned to ski at a local outing club on a rope tow in a farmer's field. Trained by ski troop veterans from the Tenth Mountain Division in WW II, they learned to respect the snow and the sport of skiing. When there was a new snowfall, everyone had to foot pack the snow before the rope tow would start running.

As the years progressed, the brothers worked at the local ski area blazing trails in the summer and working on the ski patrol in the winter. In those days, a season pass cost \$25 a sobering fact given the prices of lift tickets today. The younger of the two brothers worked on maximizing air time on the theory that this would lead to less wear and tear on his skis. (There are no p values for this experiment).

Based on the leadership of local mentors, this environment served as an incubator for expert skiers and racers. A number of people became members of the US Ski Team, including Penny Pitou who won two silver medals in 1960 at the Winter Olympics at Squaw Valley. On the other hand, the two brothers quit competitive racing at an early age because it made skiing seem more like work than fun.

The brothers have shared many peak experiences: learning to ski on frozen granular and crud in NH and bottomless powder out west and in Europe; skiing the headwall at Tuckerman's Ravine on Mt. Washington; skiing out of bounds at Arapahoe; and heli-skiing in Alberta. Many fond memories are based on the camaraderie of skiing with friends, sharing stories on memorable chair lift rides and over beer in the evening.

The brothers treasure their 67 consecutive winters of skiing and having the opportunity to adjust to changes in their physical condition as they have aged. Most of all, they are grateful to have been able to share the privilege of participating in the wonderful sport of skiing

**NOTES**

**PRESIDENTIAL ADDRESS**

**Tuesday, 3/7/2017**

**PRESIDENTIAL ADDRESS - OWNERSHIP**

**Carl J. Hauser**

### VTE Rates By Presence of Venous Injury

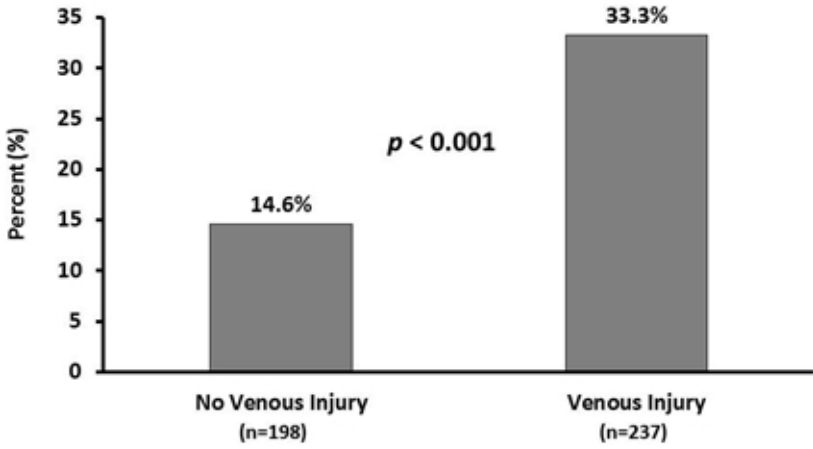

#### NOTES

**VENOUS THROMBOEMBOLISM AFTER MAJOR VENOUS INJURIES:  
COMPETING PRIORITIES**

B Frank, Z Maher, S Resnick, E Dauer, JP Hazelton, A Goldenberg, JW Cannon,  
PM Reilly, MJ Seamon  
Geisinger Medical Center, Scranton, PA

**Presenter: Brian L. Frank**  
**Senior Sponsor: Steven E. Ross**

**INTRODUCTION:** Venous thromboembolism (VTE) after major vascular injury (MVI) is particularly challenging as the competing risk of thrombosis and embolization after direct vessel injury must be balanced with risk of bleeding after surgical repair with anticoagulation. We hypothesized that venous injuries, venous repair type and systemic intraoperative anticoagulation would influence VTE formation after MVI.

**METHODS:** A multi-institution, retrospective cohort study of consecutive MVI patients was conducted at 3 urban, level-I centers (2005-2013). Patients with MVI of the neck, torso, or proximal extremities (to elbows/knees) were included. Our primary study endpoint was the development of VTE (DVT or PE). Risk factors were assessed with Chi-Square, t-test, and binary logistic regression. A  $p < 0.05$  was significant.

**RESULTS:** The 435 MVI patients were primarily young (median 27 years) males (89%) who sustained penetrating (84%) injuries. When comparing patients with VTE ( $n=108$ ) to those without ( $n=327$ ), we observed no difference in age, penetrating mechanism, extremity injury, tourniquet use, associated orthopedic and spine injuries, damage control, local heparinized saline use or vascular surgery consultation (all  $p > 0.05$ ). VTE patients had greater median ISS (17 vs. 12), shock indices (1 vs. 0.9), and more frequent torso (58% vs. 35%) and major venous (73% vs. 48%) injuries, but were less likely to receive either systemic intraoperative anticoagulation (39% vs. 53%) or postoperative enoxaparin (47% vs. 61%) prophylaxis (all  $p < 0.05$ ). After controlling for ISS, hemodynamics, injured vessel, intraoperative anticoagulation and postoperative prophylaxis, multivariable logistic regression revealed venous injury alone (Figure) was independently predictive of VTE (OR 2.7, 95%CI 1.5-4.9,  $p=0.002$ ). Multivariable analysis of the MVI subset with venous injuries ( $n=237$ ) then determined that only delay in starting postoperative VTE chemoprophylaxis (OR 1.3 per day, 95%CI 1.1-1.6,  $p=0.013$ ) independently predicted VTE formation after controlling for ISS, hemodynamics, injured vessel, surgical subspecialty, intraoperative anticoagulation and postoperative prophylaxis type. Overall, 3.4% of patients with venous injuries developed PE, but PE rates were not statistically related to their operative management (venous ligation 2.7% vs. repair 4.3%,  $p=0.72$ ).

**CONCLUSIONS:** Patients with major venous injuries are at high-risk for VTE, regardless of intraoperative management. Our results support early routine screening and immediate initiation of postoperative chemoprophylaxis in patients with major venous injuries.

**NOTES**



**IMPACT OF VENOUS THROMBOEMBOLISM CHEMOPROPHYLAXIS ON POSTOPERATIVE HEMORRHAGE FOLLOWING OPERATIVE STABILIZATION OF SPINE FRACTURES**

JP Sharpe, AM Carter, WC Gobbell, MK Palkotter, MS Muhlbauer, TC Fabian, MA Croce, LJ Magnotti  
University of Tennessee Health Science Center - Memphis, Memphis, TN

**Presenter: John P Sharpe**  
**Senior Sponsor: Martin Croce**

**INTRODUCTION:** Spine fractures following blunt trauma are often accompanied by multiple associated injuries and long periods of immobilization. Patients with these injuries are then at higher risk of venous thromboembolism (VTE). Prophylactic anticoagulation may help decrease this complication, but comes with the threat of postoperative bleeding in patients requiring stabilization of these fractures. Based on this concern, the purpose of this study was to evaluate the impact of preoperative anticoagulation on VTE and bleeding complications in patients with blunt spine fractures requiring operative stabilization.

**METHODS:** All patients with blunt spine fractures requiring operative stabilization over a 6-year period were identified. Those patients with a hospital stay less than 48 hours or those with missing data were excluded. Patients were stratified by age, gender, severity of shock, spinal cord injury, fracture location, injury severity, and timing and duration of anticoagulation. Outcomes included bleeding complications (wound hematoma/infection, development of epidural hematoma) and VTE (pulmonary embolism, deep venous thrombosis). Outcomes were then evaluated to determine risk factors for bleeding complications and VTE in the management of operative spine fractures.

**RESULTS:** 705 patients were identified: 355 patients received at least one dose of preoperative anticoagulation and 300 did not receive preoperative anticoagulation. 72% were male with a mean ISS and GCS of 21 and 14, respectively. Overall mortality was 4.9%. Bleeding complications occurred in 18 patients (2.6%) and 20 patients (2.8%) suffered VTE. Patients with VTE were more severely injured (GCS of 10 vs 14,  $p=0.007$  and ISS of 28 vs 21,  $p=0.03$ ). Despite longer time to mobilization (6.1 days vs 2.2 days,  $p<0.001$  of their scheduled preoperative doses had fewer episodes of pulmonary embolism (0.4% vs 2.2%,  $p=0.04$ ) with no difference in bleeding complications (2.1% vs 2.9%,  $p=0.63$ ) compared to patients who received either no preoperative anticoagulation or <50% of their scheduled preoperative doses.

**CONCLUSIONS:** The use of preoperative anticoagulation in patients with operative spine fractures reduced the risk of pulmonary embolism without increasing bleeding complications. Inadequate preoperative anticoagulation provides no additional benefit over withholding anticoagulation. Thus, preoperative anticoagulation is both safe and beneficial in those patients with operative spine fractures.

**Table 1. VTE characteristics and peak anti-Xa levels**

Patient Number	Days to VTE	Peak Anti-Xa	Admission VTE	VTE AFTER Therapeutic Level	VTE BEFORE Therapeutic Level	NEVER Therapeutic
1	22	0.15				x
2	140	<0.10				x
3	21	0.12				x
4	11	0.15				x
5	16	0.16				x
6	15	0.30*		x		
7	0	0.39*	x			
8	6	0.37*		x		
9	7	0.24*			x	
10	6	0.22*		x		
11	0	0.22*	x			
12	0	0.21*	x			

\* therapeutic anti-Xa level

**NOTES**

**Paper# 25**  
**Wednesday, 3/8/2017**

**OPTIMAL ANTIFACTOR-XA LEVELS FOR VENOUS  
THROMBOPROPHYLAXIS AFTER TRAUMA: A PRELIMINARY STUDY**

CA Karcutskie, SA Eidelson, KA Rao, AG Martin, E Ginzburg, EB Lineen,  
N Namias, CI Schulman, KG Proctor  
University of Miami Leonard M. Miller School of Medicine, Miami, FL

**Presenter: Charles A. Karcutskie**  
**Senior Sponsor: Nicholas Namias**

**INTRODUCTION:** Antifactor Xa (anti-Xa) levels are increasingly being used to guide thromboprophylaxis dosing in the trauma setting, but there is no definitive evidence for the optimal therapeutic target level to reduce venous thromboembolism (VTE) rates in this population. We hypothesize that achieving 0.2-0.4 IU/ml anti-Xa levels will decrease VTE rates after trauma.

**METHODS:** Admission anti-Xa levels were prospectively measured in 137 intensive care unit patients sustaining blunt or penetrating trauma or burn injury from 1/2015-1/2016. All received mechanical and initial enoxaparin (30mg BID subcutaneous) thromboprophylaxis. Subsequently, anti-Xa levels were drawn after each third dose, until a therapeutic peak level of 0.2-0.4 IU/mL was achieved. Enoxaparin dose was adjusted to a maximum of 60 mg BID subcutaneous based on the anti-Xa level.

**RESULTS:** Therapeutic levels were achieved initially in 46 (33.6%) patients, and achieved later in 35 (25.5%) additional patients, giving an overall therapeutic rate of 59.1% (n=81). Three VTEs occurred at admission and one occurred prior to dosing to an anti-Xa level of 0.2-0.4 IU/mL. Excluding these, the cohort consisted of 133 patients (77 therapeutic and 56 nontherapeutic). There was no difference in VTE (5.1% vs. 8.9%, p=0.280), DVT (2.6% vs 5.4%, p=0.309), or PE (2.6% vs 1.8%, p=0.756) rates between those who became therapeutic and those who did not. VTE characteristics along with peak anti-Xa levels are shown in table 1. Additionally, those with a BMI>30 were less likely to achieve an initial therapeutic level (19.0% vs 40.0%, p=0.019), but this difference dissolved when therapeutic levels were achieved.

**CONCLUSIONS:** An anti-Xa level of 0.2-0.4 IU/ml is not therapeutic in trauma patients. This anti-Xa level did not prevent post trauma VTE on admission or during recovery. Furthermore, 0.2-0.4 IU/ml anti-Xa levels were never achieved in some VTE patients despite repeated dosing over a >10 day period. This provides further evidence that other targets for thromboprophylaxis, such as platelets, should be considered.

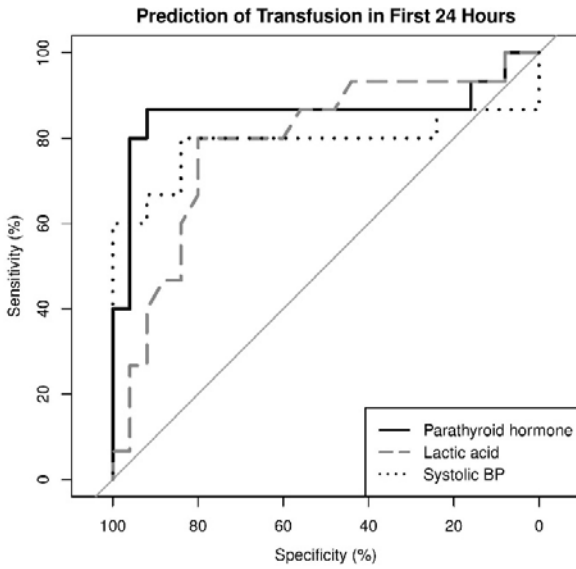

**NOTES**

**Paper# 26**  
**Wednesday, 3/8/2017**

## **PARATHYROID HORMONE AS A MARKER OF HYPOPERFUSION IN TRAUMA**

SC Fligor, KM Love, BR Collier, ME Hamill, DI Lollar, EC Bradburn  
Virginia Tech Carilion School of Medicine, Roanoke, VA

**Presenter: Scott C Fligor**  
**Senior Sponsor: Bryan R Collier**

**INTRODUCTION:** Hypocalcemia is associated with increased injury severity, need for massive transfusion, and increased mortality in trauma patients. Parathyroid glands respond immediately to changes in serum calcium, thus parathyroid hormone (PTH) levels adjust within minutes. PTH has a rapid half-life of 3-5 minutes. We hypothesized that serum PTH can serve as a measurement of perfusion after injury.

**METHODS:** A prospective observational study was performed at a Level 1 trauma center in consecutive adult patients receiving the highest level of trauma team activation. PTH and lactic acid were added to the standard laboratory panel drawn in the trauma bay on arrival. Exclusion criteria included chronic kidney disease, disorders of calcium or parathyroid regulation, bone malignancy, pregnancy, or receiving blood products prior to obtaining sample. Sample size was calculated to detect a difference of 25pg/mL in PTH with 80% power. Student's t-test was used to compare means and Chi-Square tests were used to compare proportions. Area under the receiver operating characteristic curve (AUC) was used to compare PTH, lactic acid, and systolic blood pressure for predicting transfusion, mortality, and injury severity.

**RESULTS:** Forty patients were included (47±21 years, 85% male, ISS 12.5±8.0, TRISS .85±.24). Patients who were transfused in the first 24 hours (n=15, 3.5±1.7 units PRBCs) had significantly higher PTH (273.3 vs 81.9 pg/mL, p=0.017) and lactic acid (5.6±4.1 vs. 2.9±2.5 mmol/L, p=0.03) as well as lower systolic blood pressures (103±49 vs. 136±15 mmHg, p=0.02). For predicting need for transfusion in 24 hours, PTH has an AUC of 0.86, lactic acid is 0.79, and systolic blood pressure is 0.79. A PTH of 130 pg/nL is 80% sensitive and 96% specific for need for transfusion in 24 hours. For predicting mortality, the AUC of PTH is 0.86, lactic acid is 0.83, and systolic blood pressure is 0.73

**CONCLUSIONS:** Acute hyperparathyroidism after injury is correlated with lactic acid and systolic blood pressure, and is highly predictive of need for transfusion and mortality. Point-of-care PTH may be able to provide a real-time endpoint of resuscitation.

**NOTES**

**BASIC SCIENCE LECTURE**

**Wednesday, 3/8/2017**

**BASIC SCIENCE LECTURE:**

**TRANSLATIONAL APPROACHES TO ACUTE TRAUMATIC COAGULOPATHY**

**Mitch Cohen**

	TEVAR	Open	Non-Op	<i>p</i>
N	176	28	51	
Male, %	71.0	71.4	64.7	0.667
Median Age, y (IQR)	46 (28-60)	28 (19-51)	42 (28-54)	0.007
Median Chest AIS (IQR)	5 (4-5)	5 (5-5)	4 (4-5)	<0.001
Median ISS (IQR)	36 (29-45)	36 (34-43)	29 (24-41)	0.004
TRISS Probability of Survival, P <sub>i</sub>	0.67	0.66	0.85	<0.001
Observed Survival	0.93	0.89	0.96	0.485
Median Aortic Injury Grade (IQR)	2 (2-4)	6 (4-6)	0 (0-2)	<0.001
<b>Aortic Injury Zone</b>				<0.001
Zone 0, %	0.0	10.7	0.0	
Zone 1, %	0.0	3.6	0.0	
Zone 2, %	9.1	17.9	11.8	
Zone 3, %	81.5	57.1	51.0	
Zone 4, %	10.4	10.7	37.2	
Median Hospital Length of Stay (IQR)	16 (9-26)	16 (10-28)	16 (8-27)	0.935
Mortality for initial survivors, n (%)	12 (6.8)	3 (10.7)	2 (3.9)	1.000
In-Hospital Deaths, n (%)	10 (5.7)	3 (10.7)	2 (3.9)	0.535
Post Discharge Deaths, n (%)	2 (1.1)	0.0	0.0	1.000
Lost to Follow-Up, %	15.7	12.0	18.4	0.773
Median Follow-Up Time, m (IQR)	13.1 (5.5-35.5)	11.8 (6.6-50.8)	6.5 (2.0-22.7)	0.040

## NOTES



**Paper# 27**

**Wednesday, 3/8/2017**

**TEVAR IS THE NEW STANDARD FOR OPERATIVE MANAGEMENT OF BLUNT THORACIC AORTIC INJURY: A WESTERN TRAUMA ASSOCIATION MULTI-CENTER STUDY**

SR Shackford, CE Dunne, R Karmy-Jones, W Long III, MA Schreiber, J Watson, C Watson, R McIntyre Jr., L Ferrigno, ML Shapiro, K Southerland, JA Dunn, P Reckard, TM Scalea, M Brenner, WA Teeter  
Scripps Mercy Hospital, San Diego, CA

**Presenter: Steven R. Shackford**

**Senior Sponsor: Steven R. Shackford**

**INTRODUCTION:** The advent of thoracic endovascular aortic repair (TEVAR) significantly changed the treatment of blunt thoracic aortic injury (BTAI). We evaluated the management and outcomes of adults with BTAI at seven trauma centers.

**METHODS:** This Western Trauma Association Multicenter Study focused on the management of adult patients with BTAI at seven trauma centers between 1/1/2006 and 6/30/2016. Injury, demographic, in-hospital course of management, and post-discharge follow-up data were collected for all patients. TEVAR, open surgical repair (Open), and non-operative management (Non-Op) were compared.

**RESULTS:** There were 316 adult patients with BTAI and 57 (18.0%) were either dead on arrival or died shortly thereafter. Of the 259 who survived to treatment, TEVAR was performed in 176 (68.0%), Open repair in 28 (10.8%), hybrid TEVAR and Open repair in 4 (1.5%), and Non-Op in 51 (19.7%). The four hybrid procedures were excluded in this comparison. Data relating to the three other groups are compared in the table. Only one death attributed directly to BTAI occurred and was in the TEVAR group. The remaining 13 deaths were due to multi-system trauma or head injury. Among the 240 patients who survived to discharge, two patients died (at 9 months and 8 years post-discharge), and both were managed with TEVAR. Both deaths were due to medical causes unrelated to TEVAR. Follow-up information was available in 84.3% of TEVAR patients. Stent graft surveillance CT scans were not obtained in 30% of these patients.

**CONCLUSIONS:** TEVAR was performed in over 85% of patients who required operative management of BTAI at the seven trauma centers in our study. Compared with TEVAR, Open repair was performed in younger patients with more extensive aortic injury, but the mortality rate was similarly low. Recommended CT scan surveillance follow-up of TEVAR patients for endo-leak was not routinely obtained. Managing the risk of unrecognized delayed stent graft failure in TEVAR for BTAI remains a challenge.

**NOTES**

**Paper# 28**

**Wednesday, 3/8/2017**

**COMPLETE ABDOMINAL VISCERAL ISCHEMIA IN A WOMAN WITH CHRONIC METHAMPHETAMINE ABUSE WHO SUSTAINED MULTIPLE STAB WOUNDS**

JE Anderson, IE Brown, JM Galante, CS Cocanour  
UC Davis Medical Center, Sacramento, CA

**Presenter: Jamie Anderson**

**Senior Sponsor: Christine Cocanour**

**INTRODUCTION:** Data suggest that methamphetamine may make patients susceptible to diffuse microvascular-mediated ischemia if they experience a low flow state. This ischemia is not easily reversible and may lead to tissue necrosis despite aggressive resuscitation.

**METHODS:** We present a case of a woman with methamphetamine abuse who sustained penetrating injuries and despite careful control of her injuries, developed complete abdominal visceral ischemia.

**RESULTS:** The patient is a 44-year-old woman with a history of bipolar disorder, alcohol and methamphetamine abuse, who sustained multiple stab wounds to her left chest, anterior right neck, left lower back, and right forearm. On presentation, she was awake but confused. Toxicology screen was positive for methamphetamine and her blood alcohol level was 83 mg/dL. In the ED, Bilateral chest tubes were placed and she was intubated. She was taken to the OR and found to have lacerations to the spleen, stomach, liver, and chest wall, and multiple skin lacerations. She underwent a splenectomy and primary repairs of the stomach, liver, and skin. No ischemia was identified. On post-operative day 1, she went into shock and she was taken back to the OR. Surprisingly, she was found to have diffuse bowel ischemia, leading to total colectomy and two small bowel resections. Several hours later, she continued to be unstable and returned to the OR. She was found to have ischemia of her entire viscera, including subcutaneous tissue, muscle, distal esophagus (identified on upper endoscopy), stomach, small intestine, uterus, ovaries, and rectal stump. However, she had pulsatile mesenteric arterial flow to the bowel wall. She was made comfort care and died soon after.

**CONCLUSIONS:** This is a case of a 44-year-old woman with chronic methamphetamine abuse who had complete abdominal visceral ischemia within 48 hours of presentation with multiple stab wounds, which were not adequately explained by her penetrating injuries or macrovascular flow. Methamphetamine abuse may be associated with significant microvascular compromise, the pathophysiology of which is not yet well understood. Trauma patients who have chronic methamphetamine abuse may be at particular risk of ischemia and shock.

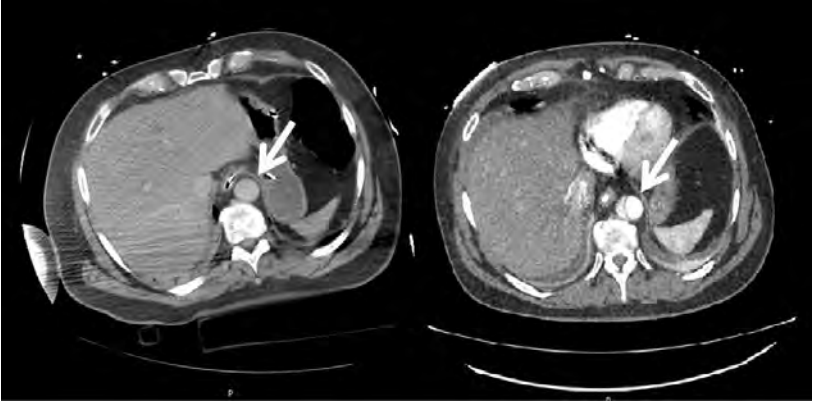

**NOTES**

**Paper# 29**  
**Wednesday, 3/8/2017**

**ACUTE AORTIC DISSECTION DUE TO SPINAL CORD PERFUSION  
PROTOCOL FOR BLUNT TRAUMATIC CORD INJURY: A CASE REPORT**

RS Smith, SE Gray  
University of Florida, Gainesville, FL

**Presenter: R. Stephen Smith and Sarah E Gray**  
**Senior Sponsor: R Stephen Smith**

**INTRODUCTION:** Aortic dissection was first reported in the autopsy of King George II in 1760. Current estimates place the incidence at 2-4 per 100,000 person years. Herein, we present the first reported case of a patient admitted with cervical spinal cord injury after blunt trauma who sustained an acute thoracic aortic dissection due to a spinal cord perfusion protocol (maintaining MAP goal >85 for cord perfusion).

**METHODS:** A 69 year old male with past history of hypertension and hyperlipidemia presented with respiratory distress and paralysis after a fall from standing. He was intubated and CT scans revealed an unstable C2 Hangman's fracture with cord injury. Neurosurgery deemed the injury non-operative, with recommendations for strict cervical spine precautions and spinal perfusion protocol (MAP goal > 85 for 7 days). On hospital day 7, he became asystolic after deep tracheal suctioning with CPR before ROSC. Following resuscitation, a CTA was obtained to re-evaluate the patient. This study revealed a Stanford Type B aortic dissection extending to the level of T11. Review of his initial trauma CT scans showed no evidence of dissection. Following this diagnosis, strict SBP goal <120 with frequent monitoring of renal and hepatic perfusion was performed. The patient continued to have normal renal and hepatic function with no signs of extension of the dissection.

**RESULTS:** The patient was discharged to rehabilitation on hospital day 15, and has since been readmitted for diaphragmatic pacer adjustment and septic shock. He expired approximately 2 months after his initial injury when his family chose comfort care.

**CONCLUSIONS:** Accepted risk factors for aortic dissection include history of hypertension and connective tissue disorders. Acute, transiently severe hypertension has also been postulated to increase risk, such as in reports of dissection in cocaine users. Our patient's dissection appears to be due to the therapeutic hypertension recommended for enhanced perfusion of spinal cord injury. This case is an example of the potentially deleterious effects of current spinal cord injury treatment guidelines that are based on level III evidence.

**NOTES**

**ALGORITHM**  
**Wednesday, 3/8/2017**

**ALGORITHM 1 - ABDOMINAL STAB WOUNDS**  
**Presenter: Matthew Martin**

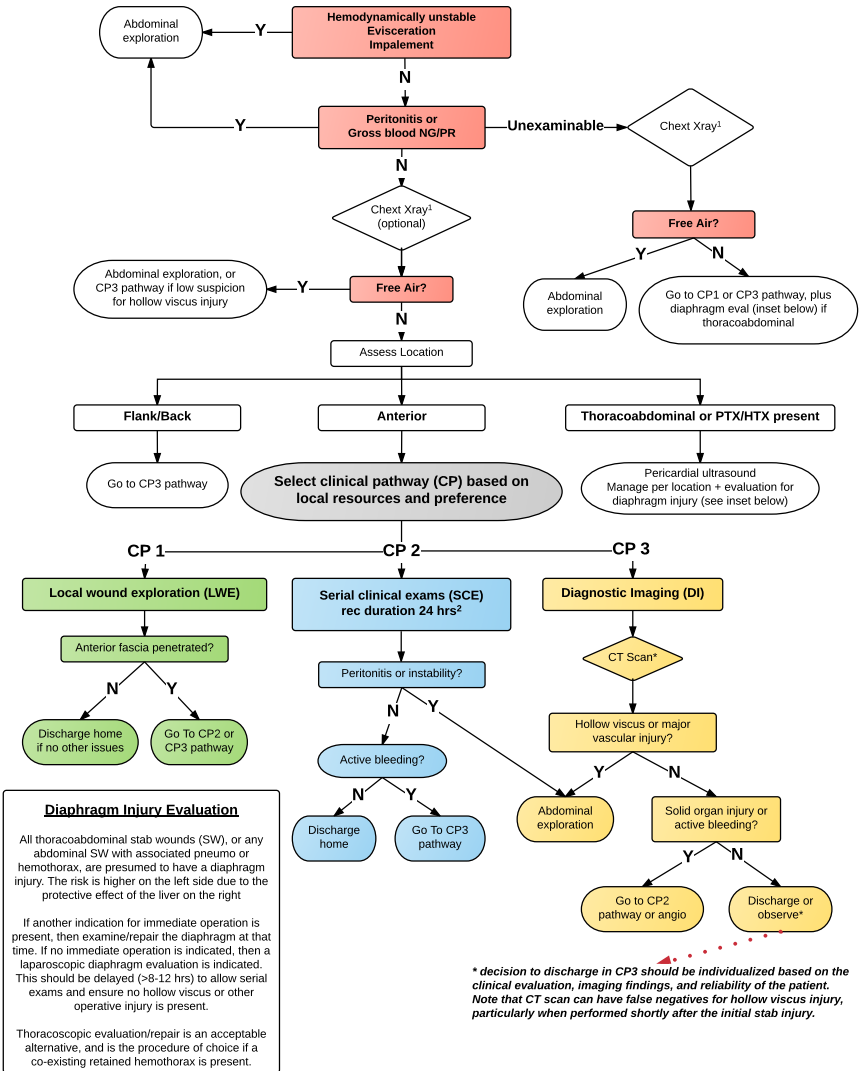

**NOTES**



**ALGORITHM**  
**Wednesday, 3/8/2017**

**ALGORITHM 2 - REBOA**  
**Presenter: Kenji Inaba**

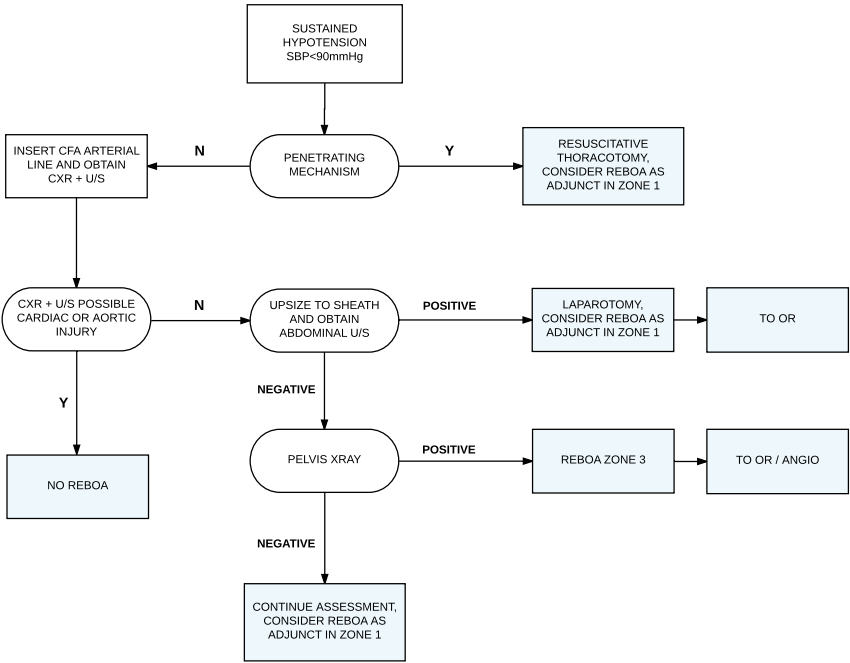

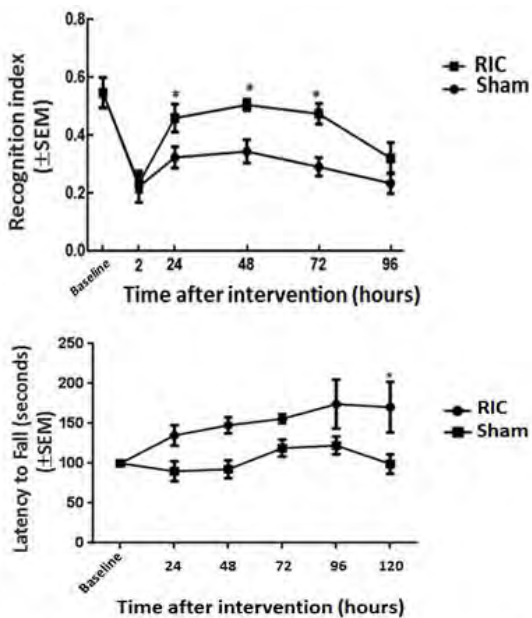

Figure 1. Cognition and Motor Coordination between RIC and Sham

NOTES

**Paper# 30**  
**Thursday, 3/9/2017**

**REMOTE ISCHEMIC CONDITIONING PRESERVES COGNITION AND MOTOR COORDINATION IN A MOUSE MODEL OF TRAUMATIC BRAIN INJURY**

B. Joseph, K. Ibrahim, R. Friese, A. Azim, A. Tang, N. Kulvatunyou, T. O'Keeffe, L. Gries, G. Vercruyssen, P. Rhee  
The University of Arizona, Tucson, AZ

**Presenter: Bellal Joseph**  
**Senior Sponsor: Peter Rhee**

**INTRODUCTION:** Remote ischemic conditioning (RIC) is an established treatment modality shown to improve outcomes by modulating inflammatory pathways. Minimizing secondary brain injury has been the primary focus of recent clinical studies. The aim of our study was to elucidate the mechanisms and outcome by using RIC in a mouse model of traumatic brain injury.

**METHODS:** 100 male C57BL mice were subjected to a cortical controlled impact injury. Two hours after TBI, animals were allocated to RIC (n=50) or Sham (n=50). RIC was induced by six 4-min cycles of ischemia and reperfusion by clamping the exposed femoral artery. Circulating levels of S100-B, neuron specific enolase (NSE) and Glial fibrillary acidic protein (GFAP) were serially measured at 5 time points (2-, 6- and 24-hours) and (2 and 5 days) post-intervention. Animals sacrificed at day 5 were observed daily for cognition and motor coordination. Novel object recognition (measured by recognition index) and rotarod tests (measured by latency to fall) were performed. Brain sections were stained using H&E and immunohistochemical for GFAP to evaluate hippocampal CA1 area for neuronal injury at day 5.

**RESULTS:** RIC animals had significantly higher recognition index than Sham at 24-, 48 and 72-h post-intervention. Latency to fall was higher in RIC animals compared to Sham animals at all time points and statistically significant at 120-hours post-intervention Fig 1. Cognitive and motor function was preserved in RIC group compared to Sham group. On H&E staining, there was less areas of neuronal degeneration in the RIC group compared to the Sham group. On immunohistochemical staining for GFAP, less astrogliosis (astrocytes hyperplasia and hypertrophy) in Hippocampus CA1 was observed in RIC animals compared to the Sham. There was no significant difference in systemic neuronal markers between the two groups. Serum GFAP trended down while serum NSE and S100-B trended up in both RIC and Sham animals.

**CONCLUSIONS:** RIC 2 hours post-injury results in preserved cognitive functions and motor coordination in a mouse model of traumatic brain injury. RIC can preserve viability of neurons and astrocytes after traumatic brain injury. RIC after TBI can be a non-invasive and relatively easy method to improve outcome after severe TBI.

**NOTES**

**DECOMPRESSIVE CRANIECTOMY VS. CRANIOTOMY ONLY FOR INTRACRANIAL HEMORRHAGE EVACUATION: A PROPENSITY MATCHED STUDY**

FS Jehan, A Azim, P Rhee, L Gries, MN Khan, T O’Keeffe, R Friese, G Vercauysse, A Tang, B Joseph

**Presenter: Faisal Shah Jehan**  
**Senior Sponsor: Randall Friese**

**INTRODUCTION:** Decompressive craniectomy (DC) is often performed in conjunction with evacuation of intracranial hemorrhage (ICH) to control intracranial pressure (ICP) in patients with a traumatic brain injury (TBI). The efficacy of DC in lowering ICP is well established, however, its effect on clinical outcomes remains controversial. The aim of our study is to assess outcomes in TBI patients undergoing decompressive craniectomy (DC) vs. craniotomy only (CO) for the evacuation of intracranial hemorrhage.

**METHODS:** We performed a 5-year retrospective analysis of TBI patients with ICH who underwent craniotomy or craniectomy for traumatic ICH. Patients were divided into two groups: those who underwent craniotomy only (CO) and those who underwent DC. Propensity scoring matched patients in a 1:2 ratio for demographics, admission Glasgow coma scale (GCS) score, severity of injury, type and size of ICH, and anticoagulant use. Outcome measures included mortality, adverse discharge disposition (SNiF/Rehab), discharge GCS score, complications and ICU and hospital length of stay.

**RESULTS:** We reviewed 1,831 patients with TBI, of which 155 underwent craniotomy and/or craniectomy. After propensity score (PS) matching, we included 99 of those patients in our study (DC: 33, CO: 66). Matched groups were similar in age ( $p=0.68$ ), admission GCS score ( $p=0.50$ ), ISS ( $p=0.70$ ), h-AIS ( $p=0.32$ ), and intracranial bleeding characteristics. Overall, 26.3% ( $n=26$ ) of the patients died and 62.6% ( $n=62$ ) were discharged to Rehab/SNiF. There was no difference in the mortality rate (27.3% vs. 25.0%;  $p=0.99$ ), adverse discharge disposition (65.2% vs. 60.6%;  $p=0.66$ ) and discharge GCS ( $p=0.53$ ) between the DC and the CO groups. On sub-analysis of patients with severe TBI ( $GCS \leq 8$ ), there was still no difference in the outcomes between the two groups. However, patients in DC group had higher complication rates and ventilator days.

**CONCLUSIONS:** This study showed no significant difference in clinical outcomes for patients undergoing evacuation of ICH regardless of the procedure performed. DC did not appear to be superior to craniotomy alone for the treatment of acute ICH.

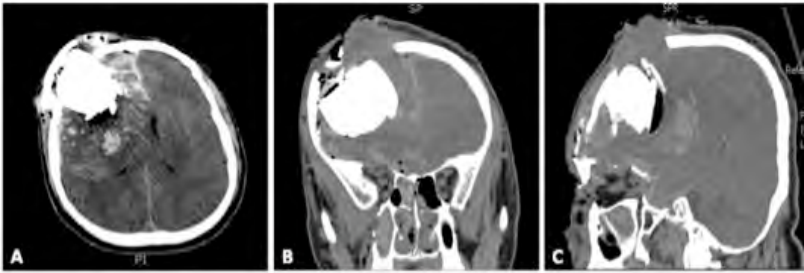

A (Axial), B (Coronal), C (Sagittal): CT images of retained intracranial explosive and associated open skull fracture and intraparenchymal and subarachnoid bleeding after a fireworks accident.

## NOTES

**Paper# 32**  
**Thursday, 3/9/2017**

**WHEN YOUR MIND IS BLOWN: MULTIDISCIPLINARY MANAGEMENT OF AN UNDETONATED INTRACRANIAL EXPLOSIVE**

RD Betzold, SA Bellister, BM Dennis, RS Miller  
Vanderbilt University Medical Center, Nashville, TN

**Presenter: Richard D. Betzold**  
**Senior Sponsor: Richard Miller**

**INTRODUCTION:** In 2015, fireworks accounted for almost 12,000 injuries, with 8,000 of those injuries occurring between the peak usage dates of June 19 and July 19. Eleven fatalities associated with firework use were reported during this time period, with 9 being associated with reloadable aerial devices. Trauma due to fireworks has been multiply reported for face, eyes, and extremities, but successful management of a retained, undetonated, intracranial aerial reload has not been described. Here, we discuss the case of a 47-year-old man who was uniquely injured with a reloadable aerial firework device.

**METHODS:** Evaluation of this case was performed by reviewing the diagnosis, treatment, and outcome of this patient in the electronic medical record. Also, a review of the literature regarding head injuries secondary to fireworks related trauma was performed utilizing dates 1950 through 2016.

**RESULTS:** This patient suffered a head injury launching an aerial firework over his head after unintentionally loading it inverted. He was intubated on the scene due to combativeness. He arrived at our trauma center in a hemodynamically stable state. Imaging revealed an open skull fracture with a repulsed foreign body, a right fronto-temporal intraparenchymal hemorrhage, and both subarachnoid and subdural hemorrhage. The patient underwent emergent right frontal craniectomy, frontal lobectomy, and removal of a foreign object. Since this was an undetonated aerial firework, a bomb squad was assembled in the operating theater and the surgeons refrained from using electrocautery until the foreign body was off the field. The patient convalesced from the operation but he ultimately required tracheostomy for ventilator management. He was ultimately discharged to a rehabilitation center on post injury day 31. In follow up, he has returned to his baseline mental status. He is also ambulating and has returned to his previous activities of daily living.

**CONCLUSIONS:** Despite the prevalence of firework related injuries, the complexities of an undetonated retained intraparenchymal explosive had not been previously reported. Our group successfully managed this in a multi-disciplinary fashion including munitions experts.

**NOTES**



**PRO-CON DEBATE**  
**Thursday, 3/9/2017**

**PRO-CON- I'M NOT DEAD YET: INITIAL EVALUATION OF TBI INJURY. CAN YOU DETERMINE SURVIVABILITY?**

**Presenter: Pro: Susan Rowell, MD and Con: Raminder Nirula, MD**

# RENAL INJURY FOUND ON CT SCAN

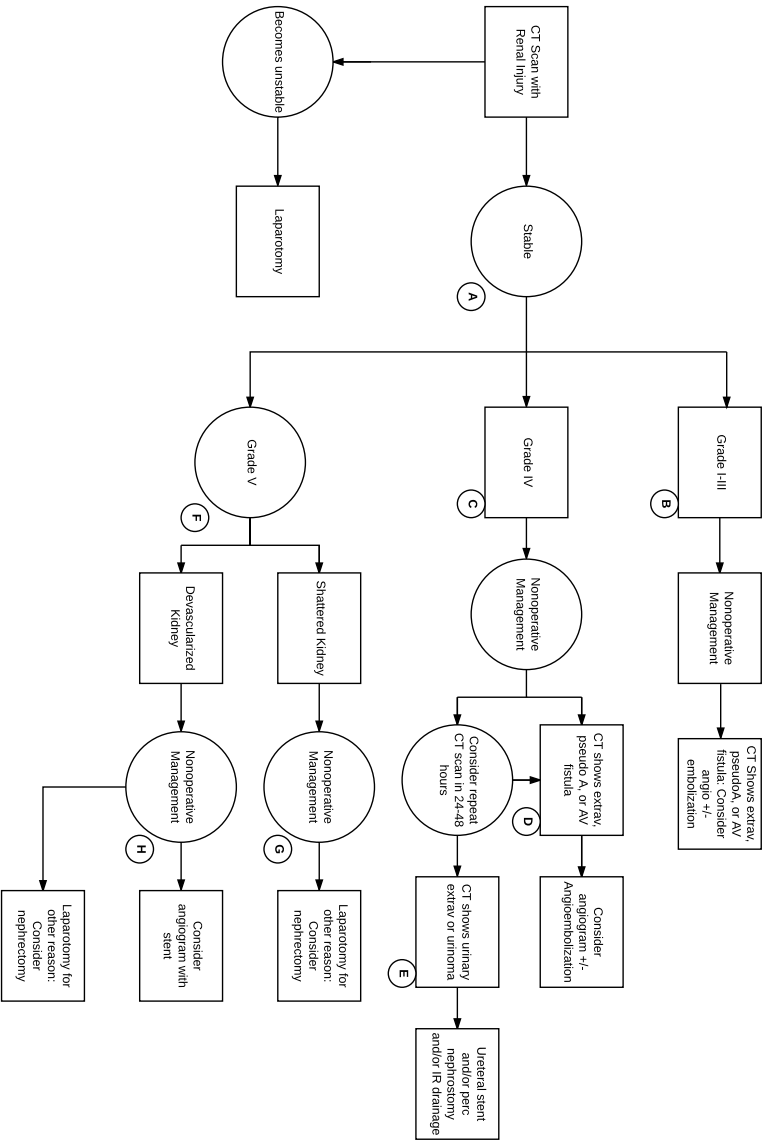

## NOTES

**ALGORITHM**  
**Thursday, 3/9/2017**

**ALGORITHM 3 - RENAL**  
**Presenter: Carlos Brown**

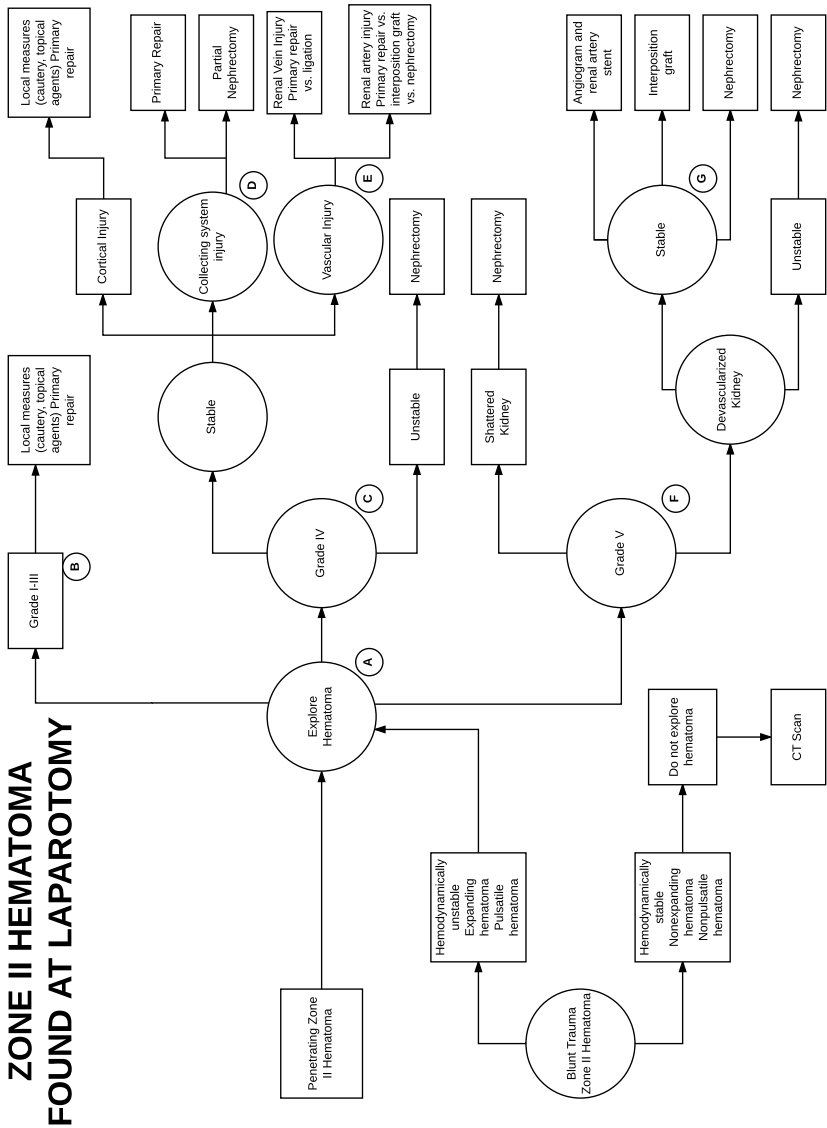

**NOTES**

**ALGORITHM**  
**Thursday, 3/9/2017**

**ALGORITHM 4 - BURNS**  
**Presenter: Gary Verduyse**

**WESTERN TRAUMA ASSOCIATION PREFERRED TRIAGE OF THE BURNED PATIENT**

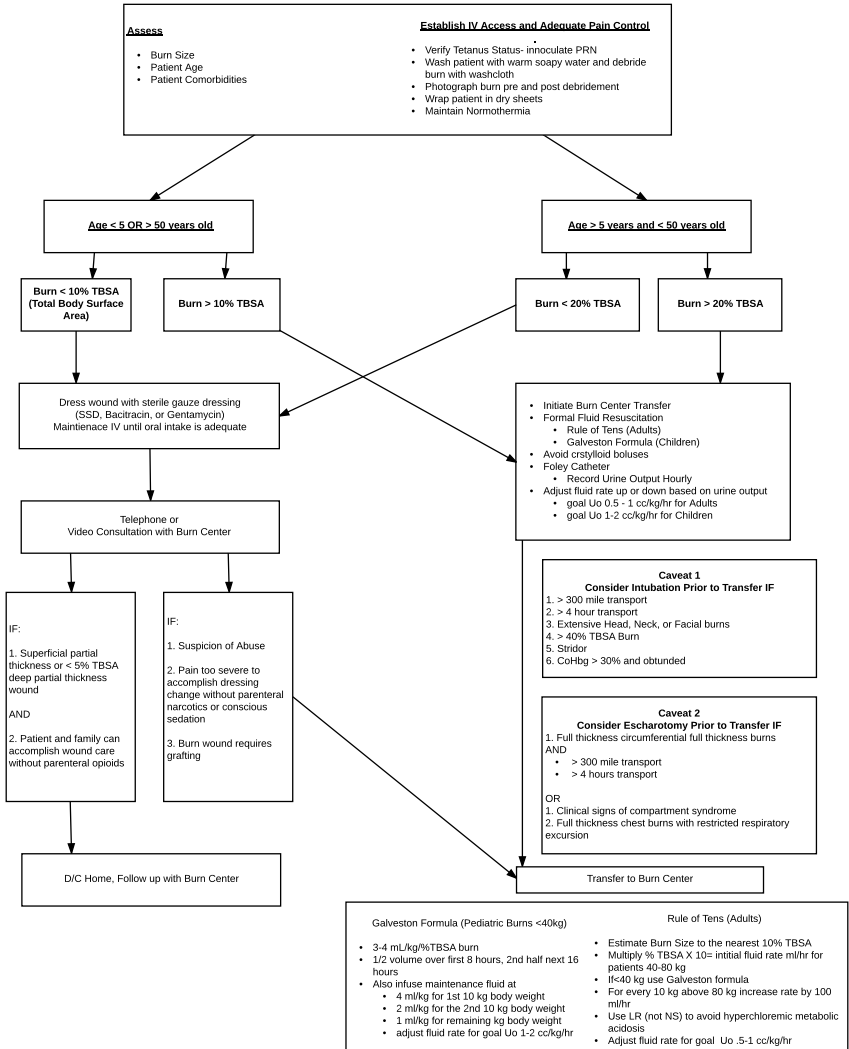

**NOTES**

**PANEL OF EXPERTS**

**Thursday, 3/9/2017**

**PANEL OF EXPERTS: THE CLASH OF GENERATIONS: WHO'S WAY IS BEST  
IN THE APPROACH TO COMMON TRAUMA PROBLEMS**

**Presenter: Moderator: Kenji Inaba**

**"Older Generation"- Tom Scalea, Jerry Jurkovich and Christine Coconour**

**"Younger Generation"- Alex Eastman, Oliver Gunter and Laura Moore**

Variable	Mortality		FSD		Complications	
	AOR (95% CI)	<i>p</i>	AOR (95% CI)	<i>p</i>	AOR (95% CI)	<i>p</i>
PTC	1.10 (0.54-2.24)	0.794	0.38 (0.15-0.97)	0.043	1.78 (0.98-3.23)	0.058
Age	1.04 (0.89-1.20)	0.639	0.88 (0.76-1.03)	0.114	1.17 (1.06-1.29)	0.002
Shock Index	2.32 (1.49-3.60)	<0.001	0.71 (0.40-1.28)	0.258	1.32 (0.96-1.81)	0.084
ISS	1.07 (1.03-1.12)	<0.001	0.92 (0.89-0.94)	<0.001	1.06 (1.04-1.08)	<0.001
GCS motor	0.55 (0.48-0.63)	<0.001	2.69 (2.39-2.97)	<0.001	0.79 (0.74-0.84)	<0.001
TC Level (Level I)	0.63 (0.36-1.11)	0.113	2.05 (0.93-4.53)	0.074	1.40 (0.83-2.39)	0.211
Case Volume	0.99 (0.99-1.00)	0.216	1.01 (1.00-1.02)	0.090	0.99 (0.98-1.00)	0.001
Injury Year	1.03 (0.97-1.10)	0.269	0.94 (0.89-0.99)	0.053	1.00 (0.96-1.05)	0.771

## NOTES



**Paper# 33**  
**Thursday, 3/9/2017**

**BIG CHILDREN OR LITTLE ADULTS? A STATEWIDE ANALYSIS OF ADOLESCENT SEVERE POLYTRAUMA OUTCOMES AT PEDIATRIC VERSUS ADULT TRAUMA CENTERS**

AT Rogers, FB Rogers, BW Gross, EH Bradburn, SB Armen, AD Cook, CD Rinehart, CA Lynch, D Wu  
Lancaster General Health/Penn Medicine, Lancaster, PA

**Presenter: Amelia Rogers**  
**Senior Sponsor: Scott B. Armen**

**INTRODUCTION:** The appropriate managing center for adolescent trauma patients is controversial. We sought to determine whether outcome differences exist for adolescent severe polytrauma patients managed at pediatric trauma centers (PTC) versus adult trauma centers (ATC). We hypothesized that no difference in functional status at discharge (FSD), complication rates, or mortality would be observed between center types.

**METHODS:** All severely injured adolescent (aged 12-17 years) polytrauma patients presenting to accredited level I-II trauma centers in Pennsylvania from 2003-2015 were extracted from the Pennsylvania Trauma Outcomes Study database. Polytrauma was defined as an Abbreviated Injury Scale (AIS) score  $\geq 3$  for two or more AIS-defined body regions. Dead on arrival, transfer, and penetrating trauma patients were excluded from analysis. ATC (n=24) were defined as adult-only centers, while standalone pediatric hospitals and adult centers with pediatric affiliation were considered PTC (n=9). A multilevel mixed-effects logistic regression model assessed the adjusted impact of center type on mortality and total complications while controlling for demographic and injury severity covariates. A generalized linear mixed model characterized FSD for non-fatal patients while controlling for the same variables.

**RESULTS:** A total of 1,606 patients met inclusion criteria (PTC: 868 [54.1%]; ATC: 738 [45.9%]), 139 (8.66%) of which died in-hospital. Univariate analyses found no significant difference in ISS (PTC: 30.9  $\pm$  11.0, ATC: 29.9  $\pm$  10.8; p=0.085), shock index (PTC: 0.854  $\pm$  0.437, ATC: 0.849  $\pm$  0.348; p=0.798), or GCS motor score (PTC: 4.35  $\pm$  2.25, ATC: 4.29  $\pm$  2.26; p=0.630) between center types, although patients treated at PTC were significantly younger than ATC counterparts (PTC: 15.2  $\pm$  1.64 years, ATC: 15.9  $\pm$  1.23 years; p<0.001). In adjusted analysis, no significant difference in mortality (AOR: 1.10, 95%CI 0.54-2.24; p=0.794; AUROC: 0.89) was observed between designations, however, FSD (AOR: 0.38 95%CI 0.15-0.97; p=0.043) was found to be lower and total complication trends higher (AOR: 1.78 95%CI 0.98-3.32; p=0.058) at PTC for adolescent polytrauma patients (Table 1).

**CONCLUSIONS:** While the optimal treatment facility for adolescent patients is frequently debated, our results suggest patients aged 12-17 presenting with polytrauma may experience improved overall outcomes when managed at adult compared to pediatric trauma centers.



**NOTES**

**Paper# 34 - FAMILY ABSTRACT**  
**Thursday, 3/9/2017**

**SAVING LIVES OUTSIDE THE HOSPITAL: A FAMILY AFFAIR**

RS Miller

Vanderbilt Univeristy Medical Center, Nashville, TN

**Presenter: Richard S. Miller**

**Senior Sponsor: Richard S. Miller**

INTRODUCTION: The surf was strong and the undertow treacherous last Memorial Day Weekend as the Miller Family vacationed in Santa Rosa Beach, Florida. Closer to the end of the week, red flags turned to yellow and sunbathers ventured back in the ocean. My oldest daughter, Alyssa and I were enjoying a swim together and talking about life when she noticed a lady waving her hands frantically. Then Alyssa saw the unimaginable: a body floating face down near the edge of the surf. The lifeless drowning victim popped up within feet of my wife, Karen, a critical care cardiac nurse and youngest daughter Stephanie, who were both relaxing on lounge chairs reading their favorite novels. They both sprung into action, Stephanie calling 911 and Karen heaving the water-bloated man to shore and evacuating liters of salt water and starting CPR. I arrived soon after and we both performed CPR for what felt like forever! At the same time, the girls escorted lifeguards and paramedics to the scene. As they whisked the patient away, we all hugged each other in a state of physical and emotional exhaustion, wondering if this poor man had any chance of survival.

Just over a year later, sitting at a stop light, I notice a car driving erratically and then crashing head on with a telephone pole. The elderly lady staggered out of the car and collapsed. 2 cars in front of me was Gretchen Edwards, one of our second year surgical residents. We and others carefully moved the patient to the grassy knoll. She was diaphoretic, pale and then pulseless and apneic. Once again, we started CPR for over 10 minutes before Nashville Fire arrived. I placed a King airway, slapped on the AED pads: V.Fib!! 2 shocks and more CPR. Then we notice her color improve and eyes open. The paramedics placed her on a backboard and transported her the 4 blocks to Vanderbilt's Trauma Center. I warned my partner, Oscar Guillamondegui that she was on her way.

**NOTES**

**PAINT THE CEILING LECTURE**

**Thursday, 3/9/2017**

**PAINT THE CEILING LECTURE: FROM THE OTHER SIDE:  
MY DAUGHTER, CANCER AND ME**

**Presenter: Ken Waxman**

**NOTES**

**Paper# 35**  
**Friday, 3/10/2017**

**THE NATURAL HISTORY OF SPLENIC VASCULAR ABNORMALITIES  
AFTER BLUNT INJURY: A WESTERN TRAUMA ASSOCIATION  
MULTICENTER TRIAL**

BL Zarzaur, JA Dunn, B Leininger, M Lauerman, K Shanmuganathan, K Kaups, K Zmary, J Hartwell, A Bhakta, J Myers, S Gordy, SR Todd, E Teicher, J Sperry, A Privette, A Allawi, CC Burlew, A Maung, K Davis, T Cogbill, S Boone, D Livingston, R Coimbra, R Koz  
Indiana University School of Medicine, Indianapolis, IN

**Presenter: Ben L. Zarzaur**  
**Senior Sponsor: Ben L Zarzaur**

**INTRODUCTION:** Following blunt splenic injury (BSI) there is conflicting evidence in the literature regarding the natural history of a splenic pseudoaneurysm (PSA vascular abnormality within the splenic parenchyma) and blush (BLUSH free extravasation outside the splenic parenchyma). The purpose of this study was to describe the current management and outcomes of patients with PSA or BLUSH.

**METHODS:** Data was prospectively collected on adult ( $\geq 18$ ) patients from 18 trauma centers admitted with a BSI and a PSA, BLUSH or PSA+BLUSH diagnosed on admission CT scan. Demographic, physiologic, radiographic, management and injury characteristics were gathered. Univariate and multivariate analysis were used to determine factors associated with splenectomy.

**RESULTS:** Two hundred patients with a vascular abnormality on CT scan (17.5% PSA; 71.5% BLUSH; 11% PSA+BLUSH) were enrolled. Overall, 14.5% had a splenectomy within 24 hours of admission without other interventions, 66.5% had angiography and 19% were observed. Of PSA only, 5.7% had urgent splenectomy, 8.5% were observed, and 85.7% underwent angiography of which 90% underwent embolization. There were no late splenectomies for those managed with observation or with angiography. For those with BLUSH only, 17% underwent immediate laparotomy and 22.3% were observed; 60% underwent angiography and of those 86% had embolization and only 1 required splenectomy. Of the 14% who had no embolization, 3 required splenectomy and 1 required repeat angiography with embolization. Of the 22.3% of patients with BLUSH who were observed, 3 required subsequent angiography and 1 splenectomy. For those with PSA+BLUSH, 9% underwent urgent laparotomy, 77.3% had angiography and 13.6% observation only. Of those managed with angiography, 100% had embolization, and 23.5% required subsequent splenectomy. Overall, admission hypotension was the strongest predictor of the need for splenectomy (OR 3.9; 95%CI: 1.2 - 12.0)  $p < 0.05$ .

**CONCLUSIONS:** In the largest reported series of patients with BSI and vascular abnormality on admission CT scan, the vast majority of patients are managed with angiography and usually embolization while splenectomy remains a rare event. However, patients with both a PSA and BLUSH were identified as high-risk group for failure of non-operative management following successful angioembolization. This group may warrant closer observation or an alternative management strategy.

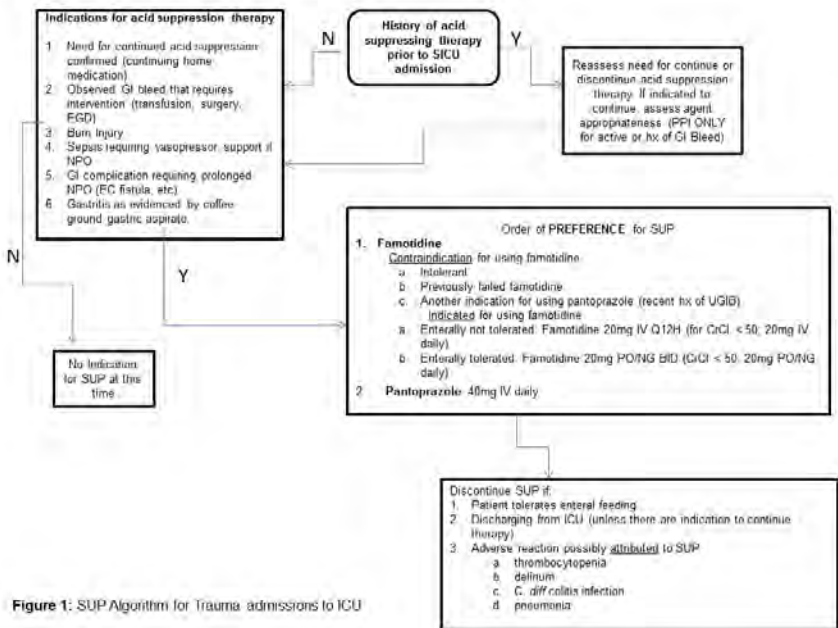

Figure 1: SUP Algorithm for Trauma admissions to ICU

**NOTES**



**Paper# 36**  
**Friday, 3/10/2017**

### **STRESS ULCER PROPHYLAXIS IS NOT NECESSARY IN THE CRITICALLY ILL TRAUMA PATIENT**

A Kunac, NA King, K McKenzie, JA Bailey, DH Livingston  
Rutgers, New Jersey Medical School, Newark, NJ

**Presenter: Anastasia Kunac**  
**Senior Sponsor: Anastasia Kunac**

**INTRODUCTION:** Current recommendations are that all critically ill trauma patients receive chemical stress ulcer prophylaxis (SUP). We assert that the potential benefit of routine SUP in critically ill trauma patients may not be justified due to lack of therapeutic efficacy in preventing significant GI bleeding (GIB) as well as potentially increased rates of pneumonia (PNA) and Clostridium difficile (Cdiff) colitis.

**METHODS:** Prospective protocol to withhold SUP (see Figure) instituted for all adult trauma patients admitted to ICU over fifteen months (10/1/14-12/31/15). Outcomes were: clinically significant GIB (requiring transfusion or endoscopic intervention), PNA, Cdiff.

**RESULTS:** 369 trauma patients were admitted to the SICU during the study period. 76% were male, mean age  $48 \pm 20$  yrs, and mean ISS  $21 \pm 10$ . 261 patients received no acid suppression medications (AS-). Acid suppression (AS) medications were initiated (AS+) on 108 patients (29%) for reasons as follows: protocol violation (n=65), home medication (n=16), gastritis (n=15), and prolonged NPO (n=6). Six patients received AS therapy after developing GIB. Eight patients (2%) had GIB. Four of the GIB (50%) were not preventable with SUP: lower GIB (n=2), hemobilia (n=1), and Mallory Weiss tear (n=1). The etiology of GIB in one AS- patient could not be determined. Of the 3 remaining patients with GIB, one had received SUP (protocol violation). Comparing AS+ to AS- patients, there was no difference in age, sex, ISS, or mortality. AS+ patients had increased vent days ( $12 \pm 16$  vs.  $5 \pm 8$ ;  $p < 0.001$ ), increased rates of C. diff (9% vs. 2%;  $p = 0.005$ ), and increased rates of PNA (38% vs. 26%;  $p = 0.016$ ). The rate of preventable GIB was not different between those who received SUP and those who did not.

**CONCLUSIONS:** Withholding stress ulcer prophylaxis has no effect on rate of clinically significant gastrointestinal hemorrhage. However, increased rates of nosocomial pneumonia and Clostridium difficile colitis and increased duration of mechanical ventilation associated with SUP administration are substantial. Routine stress ulcer prophylaxis should not be administered to critically ill trauma patients.

N=8,471		Mortality Model		Complication Model	
Variable	Adjusted Odds Ratio (95% CI)	p-value	Adjusted Odds Ratio (95% CI)	p-value	
Phase					
1	Reference	-	Reference	-	
2 (HRGP)	0.98 (0.73-1.34)	0.957	0.59 (0.47-0.73)	<0.001	
3 (HRGP + ACT Alert)	0.67 (0.47-0.94)	0.013	0.70 (0.57-0.87)	0.001	
Age	1.07 (1.05-1.09)	<0.001	0.99 (0.98-1.01)	0.319	
ISS	1.11 (1.10-1.12)	<0.001	1.09 (1.08-1.10)	<0.001	
RTS	0.37 (0.33-0.43)	<0.001	1.12 (1.00-1.25)	0.042	
AUROC: 0.87			AUROC: 0.73		

## NOTES

**Paper# 37**  
**Friday, 3/10/2017**

**IMPROVED OUTCOMES IN ELDERLY TRAUMA PATIENTS WITH THE IMPLEMENTATION OF TWO INNOVATIVE GERIATRIC-SPECIFIC PROTOCOLS**

EH Bradburn, BW Gross, PK Kim, CW Schwab, FB Rogers  
Penn Medicine Lancaster General Health, Lancaster, PA

**Presenter: Eric H. Bradburn**  
**Senior Sponsor: Scott B. Armen**

**INTRODUCTION:** Elderly trauma care is challenging due to their unique physiology, polypharmacy, and comorbidities. To improve the care of these patients, two practice management guidelines (PMG) were implemented: the High Risk Geriatric Protocol (HRGP) which triages patients based on injury patterns and comorbid conditions, surveying for occult hypotension, and the Anticoagulation and Trauma (ACT) Alert which is designed to streamline the care of geriatric TBI patients on anticoagulants. We hypothesized that both the HRGP and ACT Alert would decrease mortality and complications in geriatric trauma patients.

**METHODS:** Geriatric (aged  $\geq 65$ ) blunt trauma patients presenting to our level II center from January 2000 to July 2016 were extracted from the trauma registry. DNR patients were excluded from analysis. The study period was divided into 3 phases: Phase 1) no PMGs in place (2000-January 2006); Phase 2) HRGP only (February 2006-February 2012); and Phase 3) HRGP + ACT Alert (March 2012-July 2016). Multivariate logistic regression models assessed adjusted mortality and complications during these phases to quantify the impact of these protocols. Statistical significance was set at  $p < 0.05$ .

**RESULTS:** A total of 8,471 geriatric trauma patients met inclusion criteria. Overall complication rate was 7.8% (Phase 1: 11.3%; Phase 2: 6.7%, Phase 3: 6.9%) and mortality rate was 5.6% (Phase 1: 7.2%; Phase 2: 6.1%, Phase 3: 4.0%). Significant reductions in adjusted complications were found during both Phase 2 (AOR: 0.59, 95%CI: 0.47-0.73;  $p < 0.001$ ) and Phase 3 (AOR: 0.70, 95%CI: 0.57-0.87;  $p = 0.001$ ) compared to the reference control period (Phase 1). No significant change in mortality was observed during Phase 2 with the HRGP only (AOR: 0.98, 95%CI: 0.73-1.34;  $p = 0.957$ ) compared to the reference, however a 33% adjusted reduction in mortality was found during Phase 3 with the combination of both the HRGP and ACT Alert (AOR: 0.67, 95%CI: 0.47-0.94;  $p = 0.013$ ).

**CONCLUSIONS:** Geriatric trauma patients are not simply older adults. Improved outcomes can be realized with specific PMGs tailored to the geriatric trauma patients' needs.

ED SBP	Number	% Blunt	ISS	Mortality	Deaths due to Hemorrhage
All	1,706	67%	19 (10, 33)	350 (21%)	210 (60%)
≤90	394	53%	29 (18, 41)	182 (46%)	119 (65%)

**NOTES**

**Paper# 38**  
**Friday, 3/10/2017**

**MORTALITY FOLLOWING EMERGENT TRAUMA LAPAROTOMY:  
A MULTICENTER, RETROSPECTIVE STUDY**

JA Harvin, T Maxim, K Inaba, M Martinez-Aguilar, DR King, AJ Choudry, MD Zielinski, S Akinyeye, SR Todd, RL Griffin, JD Kerby, JA Bailey, DH Livingston, K Cunningham, DM Stein, L Cattin, EM Bulger, A Wilson, VJ Undurraga, MA Schreiber, JR Cherry-Bukowiec, HB Alam, JB Holcomb  
UT Health, Houston, TX

**Presenter: John A. Harvin**  
**Senior Sponsor: John Holcomb**

**INTRODUCTION:** Twenty-four years ago, hypotensive trauma patients requiring emergent laparotomy had a 40% mortality. In the interim, multiple interventions to decrease hemorrhage-related mortality have been implemented but few have documented any change in outcomes for patients requiring emergent laparotomy. The purpose of this study was to determine current mortality rates for patients undergoing emergent trauma laparotomy.

**METHODS:** A retrospective cohort of all adult, emergent trauma laparotomies in 2012-2013 at 12 Level I trauma centers were reviewed. Emergent trauma laparotomy was defined as emergency department (ED) admission to surgical start time in  $\leq 90$  minutes. Hypotension was defined as ED systolic blood pressure (SBP)  $\leq 90$  mmHg. Cause of and time to death was also determined. Continuous data presented as median [IQR].

**RESULTS:** 1,706 patients underwent emergent trauma laparotomy. The cohort was predominately young (31 years [24, 45]), male (84%), sustaining blunt trauma (67%), and with moderate to severe injuries (ISS 19 [10, 33]). The time in ED was 24 minutes [14, 39] and time from ED admission to surgical start was 42 minutes [30, 61]. The most common procedures were enterectomy (23%), hepatorrhaphy (20%), enterorrhaphy (16%), and splenectomy (16%). Damage control laparotomy (DCL) was utilized in 38% of patients. Hypotensive patients were more likely to undergo thoracotomy (26% versus 13%,  $p < 0.001$ ). Mortality and deaths due to hemorrhage are shown in the table.

**CONCLUSIONS:** Overall mortality rates of a trauma laparotomy is substantial (21%) with uncontrolled hemorrhage accounting for over 60% of the deaths. The mortality rate for hypotensive patients appears unchanged over the last 24 years and is even more concerning, with almost half of patients presenting with a SBP  $\leq 90$  mmHg dying. Given the already short amount of time to the OR for these patients, additional field or ED interventions to stem hemorrhage may be necessary.

**NOTES**

**PANEL OF EXPERTS**

**Friday, 3/10/2017**

**Panel of Experts: Case Records of the Joint Trauma Systems:  
A WTA Expert Panel**

**Moderators: Matthew Martin and Jennifer Gurney**

**Panelists: Carlos Brown, Deb Stein, Matt Eckert, and Jim Davis**

**NOTES**



**Paper# 39**  
**Friday, 3/10/2017**

## **HUMAN ADIPOSE-DERIVED STEM CELL TREATMENT MODULATES CELLULAR PROTECTION IN A TRAUMATIC BRAIN INJURY RAT MODEL**

NS Kappy MD; S Chang PhD; WM Harris MD; M Plastini MD; T Ortiz MD;  
P Zhang PhD; JP Hazelton DO, JP Carpenter MD; SA Brown PhD  
Cooper University Hospital, Camden, NJ

**Presenter: Nikolas S. Kappy**  
**Senior Sponsor: Steven E. Ross**

**INTRODUCTION:** Traumatic brain injury (TBI) is a common cause of morbidity and mortality in the trauma population. The purpose of this study is to examine the effects of human adipose-derived stem cell (ASC) treatment in a rat model of TBI. We hypothesized that there would be an improvement in functional measurements of balance and coordination in animals treated with ASCs. Furthermore, we hypothesized that we would see a normalization in tumor necrosis factor (TNF- $\hat{1}\pm$ ) and neural injury marker amyloid precursor protein ( $\hat{1}^2$ -APP) levels in the treatment group, indicating enhanced cellular recovery.

**METHODS:** Sprague-Dawley rats underwent frontal TBI via a standardized closed head injury model. Rats were randomly selected to receive either intravenous human derived ASCs (TBI/ASC;n=4) or intravenous saline within 3 hours of injury (TBI control;n=4). Sham group (n=3) underwent a sham procedure without TBI. Functional recovery was evaluated pre-TBI and 3 days post-TBI using the accelerating Rotarod method. Brain tissue was isolated and assessed for cellular damage via ELISA assay for TNF- $\hat{1}\pm$  and immunohistochemical staining for  $\hat{1}^2$ -APP.

**RESULTS:** A trend was observed toward depressed functional performance on Rotarod test in the TBI/ASC group compared to sham, with recovery of function with ASC treatment. TNF- $\hat{1}\pm$  level was elevated in the TBI/ASC group when compared to the sham group (0.67 $\hat{A}\pm$ 0.04 vs. 0.39 $\hat{A}\pm$ 0.02; p<0.05) with TNF- $\hat{1}\pm$  level recovering back to normal ranges with ASC treatment (0.47 $\hat{A}\pm$ 0.01 vs. 0.67 $\hat{A}\pm$ 0.04; p<0.01). Similarly, levels of  $\hat{1}^2$ -APP were elevated in the TBI control group when compared to the sham group (fluorescence ratio: 0.69 $\hat{A}\pm$ 0.03 vs. 0.49 $\hat{A}\pm$ 0.03; p<0.01).  $\hat{1}^2$ -APP levels recovered back to normal ranges with ASC treatment when compared to TBI control group (fluorescence ratio: 0.43 $\hat{A}\pm$ 0.05 vs. 0.69 $\hat{A}\pm$ 0.03; p<0.01).

**CONCLUSIONS:** Rats treated with intravenous ASCs experienced enhanced cellular recovery in the acute phase following TBI, reflected by increased levels of TNF- $\hat{1}\pm$  and  $\hat{1}^2$ -APP in untreated rats compared to ASC treated rats. Additionally, a trend toward enhanced functional recovery was seen with Rotarod data in ASC treated rats, suggesting a possible functional healing advantage to ASC treatment. These data demonstrate the potential for ASC treatment modalities to aid in cellular protection and functional recovery following TBI.

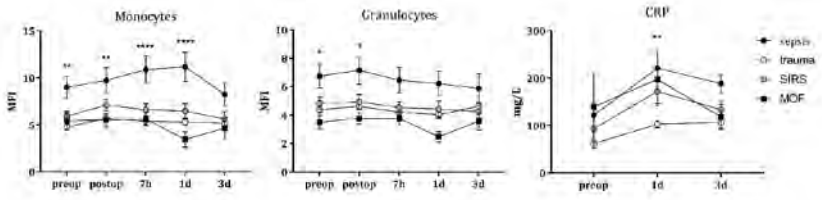

**NOTES**

**MONOCYTE L-SELECTIN EXPRESSION AS AN EARLY BIOMARKER FOR POST-INJURY SEPSIS**

GD Briggs, NJ Lott, T DeMalmanche, ZJ Balogh  
University of Newcastle, Newcastle, NSW

**Presenter: Gabrielle Briggs**  
**Senior Sponsor: Zsolt Balogh**

**INTRODUCTION:** Severe traumatic injury is associated with systemic inflammatory response syndrome (SIRS) which could lead to sepsis and multiple organ failure (MOF). Early differentiation of SIRS and sepsis in critically injured postoperative patients is challenging. L-selectin is expressed on leukocytes to mediate endothelial rolling and is shed upon leukocyte binding, leading to measurable soluble L-selectin in the plasma which is associated with decreased chance to develop and increased chance to survive sepsis. We hypothesise that the expression of L-selectin on leukocytes will serve as a more direct marker of early inflammatory processes preceding sepsis.

**METHODS:** Peripheral blood from 101 major trauma patients [mean age(SD):44(18), male:78%, ISS:18(12), BD:-1.8(3.9)] requiring major non-lifesaving secondary orthopaedic intervention was collected at across the perioperative period(fig1). L-selectin expression was measured via the mean fluorescence intensity of granulocyte and monocyte populations using flow cytometry. Patients were subgrouped into: patients who developed sepsis (n=13, age:50(16), male:100%, ISS:37(11), BD:-6.2(3.3), patients who developed sterile MOF [(n=8, age:49(21), male:88%, ISS:23(15) BD:-3.3(4.0)], patients with SIRS that did not develop into sepsis or MOF [(n=15, age:39(17), male:73%, ISS:20(9.3) BD:-1.7(3.1)] and patients with uncomplicated recovery (n=65, age:41(18), male:73%, ISS:16(9.8) BD:-0.64(3.5)]. Monocyte and granulocyte L-selectin expression was compared among the four groups at each time point using two-way ANOVA (\*p<0.05, \*\*p<0.01, \*\*\*p<0.0001)

**RESULTS:** Monocyte L-selectin expression was elevated in the early postoperative period up to 24-hours in patients who later developed sepsis compared to other groups (Fig1). Granulocyte L-selectin expression was significantly elevated in patients who later developed sepsis compared to other groups at the pre-op and immediately postop time points (Fig2.). L-selectin expression in the SIRS and MOF groups did not significantly differ from the non-complicated trauma group (Fig1-2). Other cytokines and commonly used inflammatory markers like C-reactive protein, were significantly elevated in patients who later developed SIRS, sepsis and MOF compared to non-complicated patients during the early postoperative period (Fig3.).

**CONCLUSIONS:** We demonstrate that monocyte and to a lesser extent, granulocyte L-selectin expression is elevated perioperatively in patients who later develop sepsis, but not sterile MOF and SIRS. This could help in decision-making for the timing of operations, predicting prognosis and indicate the need for antibiotics.

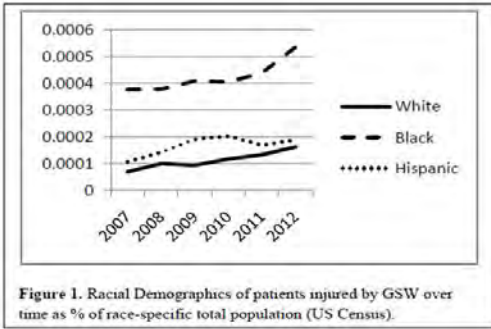

**NOTES**

**Paper# 41**  
**Friday, 3/10/2017**

**INJURIES SUSTAINED DURING CONTACT WITH LAW ENFORCEMENT  
IN THE UNITED STATES: A NATIONAL TRAUMA DATA BANK STUDY**

M Schellenberg, K Inaba, J Cho, A Strumwasser, D Grabo, C Bir, A Eastman,  
D Demetriades

LAC+USC Medical Center, Los Angeles, CA

**Presenter: Morgan Schellenberg**

**Senior Sponsor: Kenji Inaba**

**INTRODUCTION:** Injuries sustained by civilians from interaction with police are a prominent sociopolitical issue. No comprehensive studies describing these interactions have been published using national hospital-based data. The aim of this study was to examine the epidemiology of these injuries to better understand this mechanism of injury.

**METHODS:** Patients entered into the NTDB (01/2007 - 12/2012) with E-codes E970.0-E976.0 (ICD-9-CM), identifying injuries associated with law enforcement in the course of legal action, were enrolled. Patient demographics, injury characteristics, procedures, and outcomes were abstracted. Patients injured by other civilians (E960.0-E968.0) were used for comparison. Analysis was performed with SPSS.

**RESULTS:** Of 4,146,428 patients in the NTDB, 7203 (0.17%) were injured during interaction with police. The number of patients in consecutive study years was 858, 1103, 1148, 1274, 1316, and 1504. As a percentage of total enrolment in NTDB annually (which increased by 64.3% over the study), the incidence was stable (0.168-0.180%). Patients had a median age of 31 years (0-108) and 94.3% were male. Patients were 42.7% White, 30.2% Black, 17.0% Hispanic, 1.0% Asian, and 9.1% Other. The American population was 63.9% White, 19.2% Black, and 16.3% Hispanic at that time. Median ISS was 9 (IQR 4-17). The most common mechanisms of injury were gunshot wounds (GSW) (43.6%) and blunt assaults (39.8%). Mechanism, ISS, and outcomes did not vary by race.

Racial demographics were analyzed for patients injured by GSW. Rates of injury by GSW increased annually by  $1.85 \times 10^{-5}$  among Whites,  $3.16 \times 10^{-5}$  among Blacks, and  $1.61 \times 10^{-5}$  among Hispanics (Figure 1).

Compared to patients injured by civilians, patients injured by police are more likely to be White (42.7% vs 24.5%,  $p < 0.001$ ), less likely to be Black (30.2% vs 44.6%,  $p < 0.001$ ), and more likely to be shot (43.6% vs 32.0%,  $p < 0.001$ ).

**CONCLUSIONS:** As a percentage of total enrollment in the NTDB over time, the overall rate of injuries sustained by civilians during interactions with police has been stable. Gunshot wounds are the most common mechanism of injury. Proportionally, Black patients are the most frequently injured race and showed the greatest increase in incidence over time.

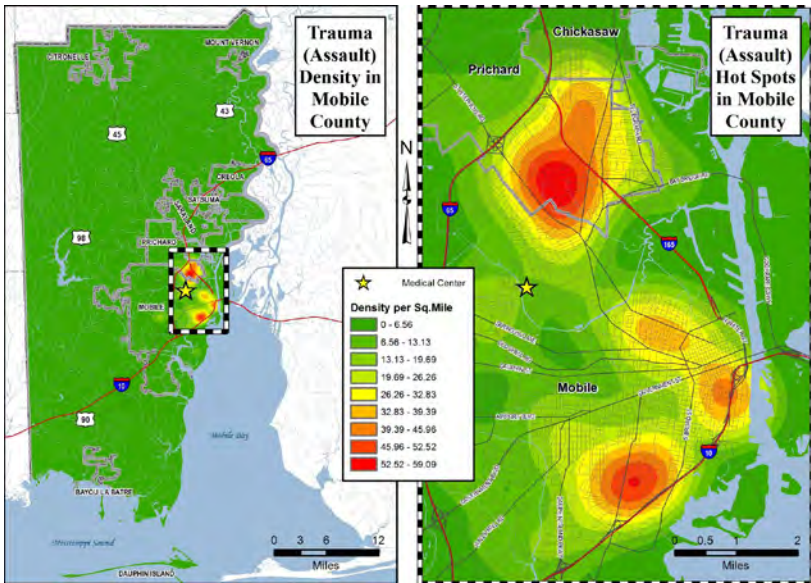

**NOTES**

**Paper# 42**  
**Friday, 3/10/2017**

**GEOSPATIAL MAPPING CAN BE USED TO IDENTIFY GEOGRAPHIC AREAS AND SOCIAL FACTORS ASSOCIATED WITH INTENTIONAL INJURY AS TARGETS FOR PREVENTION EFFORTS DISTINCT TO A GIVEN COMMUNITY**

CH Lasecki, AY Williams, FC Mujica, S Stutsman, JD Simmons, L Ding, SB Brevard  
University of South Alabama, Mobile, AL

**Presenter: Chris H. Lasecki**  
**Senior Sponsor: Matthew Martin**

**INTRODUCTION:** Geographic information systems (GIS) have proven effective in studying intentional injury in various communities; however, GIS is not implemented widely for use by level I trauma centers in understanding patient populations. Our study of intentional injury combines the capabilities of GIS with a level I trauma center registry to determine the spatial distribution of victims and correlated socioeconomic factors.

**METHODS:** 1,099 out of 3,109 total incidents of intentional trauma in the trauma registry from 2005-2015 had sufficient street address information to be mapped in GIS. Comparison of these data, coupled with demographic data at the block group level, determined if any clustering or spatial patterns existed. GIS delivered these comparisons using several spatial statistics including kernel density, ordinary least squares test, and moran's index.

**RESULTS:** Kernel density analysis identified four major areas with significant clustering of incidents. The moran's I value was 0.0318. Clustering exhibited a positive z-score and significant p-value ( $p < 0.01$ ). Examination of socioeconomic factors by spatial correlation with the distribution of intentional injury incidents identified three significant factors: unemployment, single parent households, and lack of a high school degree. Tested factors did not exhibit substantial redundancy ( $VIF < 7.5$ ). Non-significant tested factors included race, proximity to liquor stores and bars, median household income, per capita income, rate with public assistance, and population density.

**CONCLUSIONS:** Spatial representation of trauma registry data using GIS effectively identifies high-risk areas for intentional injury. Analysis of local socioeconomic data identifies factors unique to those high-risk areas in the observed community. Implications of this study may include the routine use of GIS by level I trauma centers in assessing intentional injury in a given community, the use of that data to guide the development of trauma prevention, and the assessment of other mechanisms of trauma using GIS.

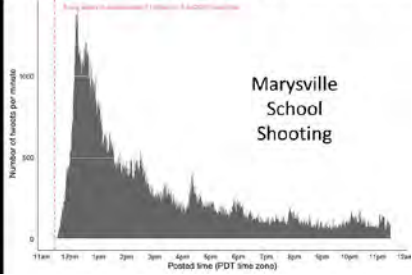
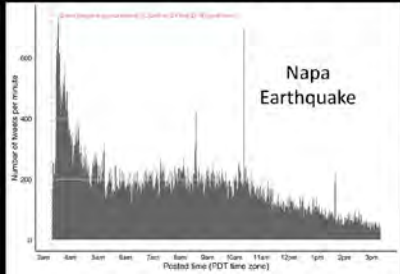
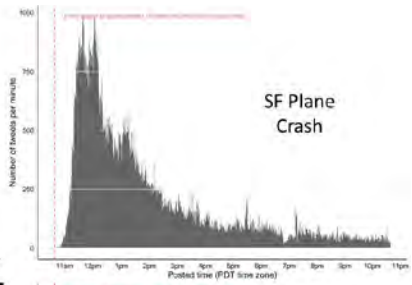
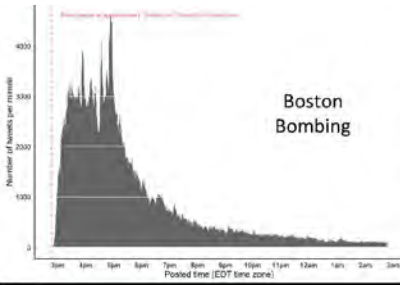

**NOTES**



**Paper# 43**  
**Friday, 3/10/2017**

**FINDING THE SIGNAL IN THE NOISE: COULD SOCIAL MEDIA BE UTILIZED FOR EARLY HOSPITAL NOTIFICATION OF MULTIPLE CASUALTY EVENTS?**

RA Callcut, S Moore S, G Wakam, AE Hubbard AE, MJ Cohen  
University of California San Francisco, San Francisco, CA

**Presenter: Rachael A Callcut**  
**Senior Sponsor: Mitchell J Cohen**

**INTRODUCTION:** Frequently, delayed notification and lack of early information hinder timely hospital based activations in large scale multiple casualty events. Social media has been utilized in other fields to predict and respond to other public health events. We hypothesized that Twitter real-time data would produce a unique and reproducible signal within minutes of multiple casualty events and we investigated the timing of the signal compared with other hospital disaster notification mechanisms.

**METHODS:** Using disaster specific search terms, all relevant tweets from the event to 7 days post-event were analyzed for 5 recent US based multiple casualty events (Boston Bombing [BB], SF Plane Crash [SF], Napa Earthquake [NE], Sandy Hook [SH], and Marysville Shooting [MV]). Quantitative and qualitative analysis of tweet utilization were compared across events.

**RESULTS:** Over 3.8 million tweets were analyzed (SH 1.8 m, BB 1.1m, SF 430k, MV 250k, NE 205k). Original tweets were 45%, retweets 55%. Peak tweets per min ranged from 209-3326. The mean followers per tweeter ranged from 3382-9992 across events. Retweets were tweeted a mean of 82-564 times per event. Tweets occurred very rapidly for all events (<2 mins) and represented 1% of the total event specific tweets in a median of 13 minutes of the first 911 calls. A 200 tweets/min threshold was reached fastest with NE (2 min), BB (7 min), and SF (18 mins). If this threshold was utilized as a signaling mechanism to place local hospitals on standby for possible large scale events, in all case studies, this signal would have preceded patient arrival. Importantly, this threshold for signaling would also have preceded traditional disaster notification mechanisms in SF, NE, and simultaneous with BB and MV. Remarkably, the tweet graphic signatures were consistent across disasters [Figure] except SH which had similar signature but, delayed signal initiation.

**CONCLUSIONS:** Social media signatures following multiple casualty events have a unique and reproducible signal across differing types of disaster scenarios. This platform is a powerful, predictable, and potentially important mechanism for optimizing disaster response and further investigation is warranted to establish optimum signal thresholds.

Table: Comparison of mean medical costs and mean ISS by road user group

Road User	Admitted		Non-Admitted		Mean Cost Difference	Mean ISS Difference
	Mean Medical Cost	Mean ISS	Mean Medical Cost	Mean ISS		
Motor Vehicle Occupant	\$40,053	9.7	\$9,373	1.4	\$30,681	8.3
Motorcyclist	\$59,901	12.4	\$8,677	2.9	\$51,225	9.5
Bicyclist	\$32,064	10.4	\$9,003	2.7	\$23,062	7.7
Pedestrian	\$82,391	15.1	\$9,391	2.6	\$73,000	12.5

## NOTES

**Paper# 44**  
**Friday, 3/10/2017**

**TRAFFIC-RELATED INJURIES- DIRECT MEDICAL COSTS OF TRAUMA-ACTIVATED INJURIES IN SAN FRANCISCO, 2012-2014**

LN Schwarcz, TB Richards, RA Dicker, C Juillard, D Bower, ML Wier  
San Francisco Department of Public Health, San Francisco, CA

**Presenter: Leilani Schwarcz**  
**Senior Sponsor: Rochelle Dicker**

**INTRODUCTION:** Vision Zero has recently been adopted in several U.S. cities to galvanize a multi-pronged approach towards eliminating traffic deaths and reducing serious injuries. For every U.S. traffic fatality there are eight traffic-related injury hospitalizations. Prioritization of injury prevention investments at the city-level requires consideration of health and economic consequences. To inform citywide prevention priorities, we analyzed the direct medical costs and severity of traffic injuries occurring in a major U.S. city, stratified by road user group, using registry data from the city's only Level I Trauma Center.

**METHODS:** We conducted a retrospective analysis using trauma registry data from 2012-2014 for transportation-related injuries on our city's public roadways. Using cost-to-charge ratios, direct medical costs were calculated using hospital, professional, and ambulance fee charges. We compared direct medical costs of injury, demographics, injury severity, and hospital admission rates among road user groups, further stratifying by admitted and non-admitted patients.

**RESULTS:** Direct medical costs to treat traffic injuries (N=4,183 patients) at the trauma center from 2012-2014 totaled \$105.5 million, including 1,438 hospitalization days. Pedestrians comprised the largest proportion of costs (44%), followed by motor vehicle occupants (22%), motorcyclists (18%) and bicyclists (16%). While only 34% of patients were hospitalized, these patients comprised three-quarters of total medical costs. Hospitalized pedestrians had the highest mean injury severity score (ISS) at 15.1, while motor vehicle occupants had the lowest (ISS=9.7). The mean medical cost for admitted pedestrians was over twice that of admitted motor vehicle occupants (Table). Comparison of medical costs between admitted and non-admitted patients by road user group showed the largest cost difference among pedestrians (\$73,000), while bicyclists had the lowest difference (\$23,062).

**CONCLUSIONS:** Study findings highlight the potential medical cost savings of shifting the distribution of injuries toward less severe injuries and reducing hospitalizations. This analysis of medical cost and injury severity identifies pedestrians as a vulnerable road user population who are most impacted by traffic injuries, medically and economically. While direct medical costs only represent approximately one-fifth of the total cost burden of non-fatal motor vehicle crashes, they are an indicator of the potential cost savings of targeted prevention investments through initiatives like Vision Zero.

**NOTES**



# MARKETING & EXHIBITOR SUPPORT

The Western Trauma Association wishes to recognize and thank the following companies for their marketing support:

CSL Behring

Cerus Corporation

Haemonetics

HCA

Instrumentation Laboratory

KLS Martin

Lifecell

PryTime Medical Devices, Inc.

Z-Medica

Zimmer Biomet



## WESTERN TRAUMA ASSOCIATION

4655 Rockcross Court  
Zionsville, IN 46077

Telephone: 678.675.2696

Fax: 678.668.7312

Web: [www.westerntrauma.org](http://www.westerntrauma.org)

Email: [info@westerntrauma.org](mailto:info@westerntrauma.org)